

# **HEADS UP!** *for Safety*

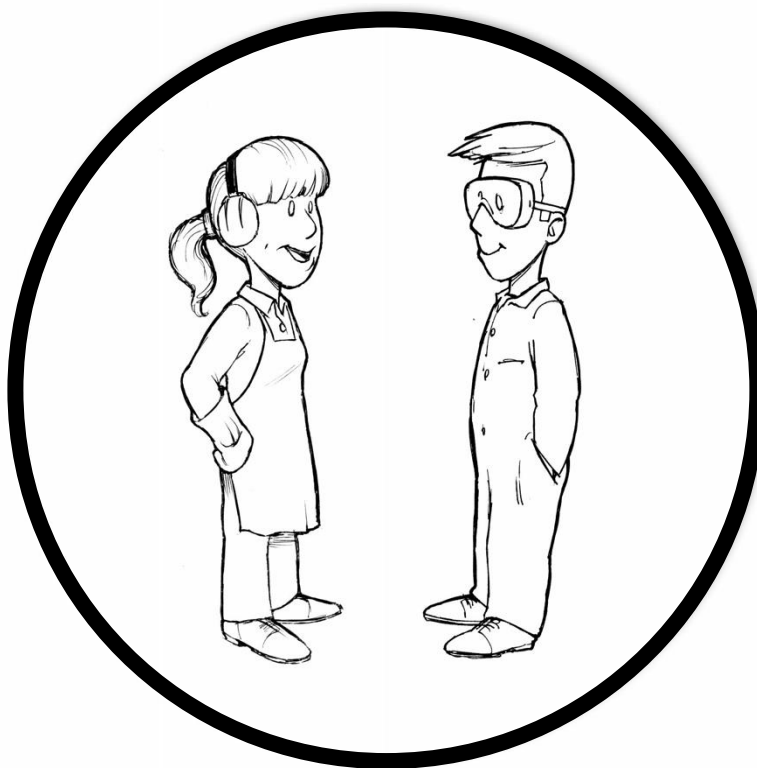

**FOR MIDDLE SECONDARY SHOP CLASSES.**

**(GRADES 6-12)**

**2018**



## Acknowledgements:

Heads Up for Safety is a safety manual for Technology Educators in B.C. It was prepared by Shop teachers, for Shop teachers with the assistance of the Schools Protection Program, Risk Management Branch of the Ministry of Finance and the Curriculum Branch of the Ministry of Education, as well as the Industry Training Authority (ITA). The goal of the project, was to update the 2002 version of the Heads Up for Safety document with new standards and additional equipment, thus providing a more comprehensive safety standard for all Technology Education and Trades training facilities.

Technical expertise for this document was provided by:

Heather Elliott	SD #33
Russell Evanisky	SD #41
Randy Grey	SD #71
Steven Claassen	SD #71
Kevin McIntyre	SD #35
Roger Bortignon	B.C.I.T



## Disclaimer

The BC Technology Education Association developed this instructional guide and materials based on the old ***“HEADS UP! for Safety”*** manual and general shop safety measures being practiced in high school shops. The aim is to assist in the prevention and reduction of injury and disease in technical education shops in BC secondary schools. However, the BCTEA cannot and do not warrant the accuracy or the completeness of this instructional guide and materials, and as a result, they will not be liable to any person or organization for any loss or damage of any nature, whether arising out of negligence or otherwise, which may be occasioned as a result of the use of this instructional guide and materials.

Ministry of Education (EDUC) has participated in the development of this instructional guide and materials. The aim is to assist in the prevention and reduction of injury and disease in technical education shops in BC schools. However, EDUC cannot and does not warrant the accuracy or the completeness of this instructional guide and materials, and as a result, will not be liable to any person or organization for any loss or damage of any nature, whether arising out of negligence or otherwise, which may be occasioned as a result of the use of this instructional guide and materials.

## Introduction

Educators have a responsibility, to both students and their parents, to provide a safe learning environment in which the risk of personal injury is low. For technology educators, however, this responsibility is compounded by the fact that students generally have little or no experience working in hazardous environments where the knowledge of risks and the need for safe work practices are crucial.

This handbook was designed to provide you, the instructor, with assistance in your efforts to teach specific skills and best practices within the context of a broader shop safety program. In support of the safety-related learning outcomes prescribed by the Applied Design, Skills and Technologies curriculum, this handbook outlines best practices and minimum standards required in shop classes throughout BC in an effort to keep students safe and to provide them with an awareness of the importance of safety in the workplace.

The title *“HEADS UP! for Safety”* was designed to attract the attention of people who deal with their own and other’s safety—people who are in a position to reduce the number of accidents by following safe work practices. It symbolizes a need for awareness and caution about the environment they are in, and for the well-being of themselves and others.

The phrase “Heads Up” is used throughout the English-speaking world to draw people’s attention to something that is happening around them—someone passing close by, an object moving within close range, a signal of danger ahead, etc. Whenever and wherever the phrase is used, it is generally in relation to safety.

Students are, or soon will be, part of the workforce. Technology education classes provide a perfect opportunity to teach them about the importance of safety in the work place while providing them with skills they need to get ahead.

## Implementing Safety in a Technology Education Program

Educating students about shop safety can be a challenge—how do you provide them with enough information to ensure their safety without overwhelming them or losing their interest? And what do you do about those students who are inclined to disregard safety instructions with a wave of bravado and misplaced confidence? Unfortunately, we can't solve the problems in your shop area, but we can offer you some suggestions on how to build safety into your current and future programs.

We suggest that a technology education safety program be organized into manageable units that focus on the important safety points and repeat the crucial ones. Following is an outline of the process we recommend for integrating safety into your shop program:

1. Provide an introductory lesson about safety in shop settings for all students entering a technology education program. Alert students to the health and safety issues that arise, the roles and responsibilities of everyone involved, as well as appropriate attitudes in the work place.
2. Supply basic safety instruction on the general use of hand tools and the handling of industrial materials. This lesson could be given to students before they move from the design phase of a project to the implementation stage.
3. Give a general overview on the safe use of portable power tools for all students enrolled in shop programs.
4. Discuss generic safety considerations and procedures that apply to the use of all stationary power tools and equipment. This lesson could be given to students as they approach the phase of their project work that requires the use of power tools.
5. Provide instruction and testing on the safe use of each power tool before qualifying students to use the tool in the school shop.

## Implementing Safety in a Technology Education Program (cont.)

When giving a lesson on a particular tool, describe (simply and briefly) **and** demonstrate the tool and how it operates. Each lesson should cover the following areas:

- purpose of the tool;
- operation of the tool;
- potential hazards of the tool; and
- controlling the hazards

In teaching about potential hazards, students should be encouraged to think about the action/reaction that takes place between the tool and the material—does the action of the tool threaten kickback? Eject debris? Generate heat? If students learn to ask and answer these kinds of questions for themselves, they will have acquired a valuable skill in regards to their own and others' safety—**the ability to predict and control hazards.**

When a teacher makes safety an integral part of the instructional program, it is learned in much the same manner as skills and operations. However, safety can also be 'caught' as readily as 'taught,' implying that proper safety attitudes and practices are contagious and their development strongly influenced by the teacher's attitude and conduct in the shop. Safety does not just happen, but is the result of a well-planned program administered and modeled by the technology education teacher.

### **Scenario 1: Table Saw Accident**

**A student using a table saw had three fingers severed when the dado blade caught on the wood, forcing the wood to slip away from the blade exposing the hand to the saw. The student was not using a push stick, and a proper guard was not in place.**

**Safety tip: Students need to be instructed to use a push stick or feather stick and proper guards need to be installed and used.**

## Suggested Strategies

Teaching and implementing safety in a technology education program does not have to be dry or boring. You want your students to be attentive to what you are teaching them, for it may mean their life and/or the lives of those around them—including yours!

From an instructional perspective, there are two main approaches to teaching safety in the shop area—separated and integrated. You will likely include elements of both styles in your safety program.

- The **separated approach** is where you design and teach individual units on specific safety topics such as lab conduct, general use of hand and power tools, proper clothing, eye safety, hearing protection, use of fire extinguishers, reporting of unsafe conditions and accidents, etc.
- The **integrated approach** is where you design and teach units on skill development and/or machine operation that include safe use and practice. This approach allows you to integrate safety as ‘part and parcel’ of the skill being taught.

Following are some recommended strategies for implementing safety training into your existing shop programs.



## Suggested Strategies (cont.)

### Demonstration

“Actions speak louder than words” is a phrase that is well suited to classroom instruction about safety, particularly for shop students who chose your class because they want to “do” something rather than listen to another lecture. A variety of means can be used to demonstrate safety:

- Demonstrate the set-up and operation of each machine.
- Set up the shop to replicate a hazardous work area (e.g. spills on the floor, locker doors left open, power tools left turned on, extension cords where they can trip people, safety guards detached from the equipment, improper storage of hazardous materials, empty fire extinguishers, emergency exit blocked). Then ask the students to carefully conduct a health and safety inspection of the shop, and have them explain what is wrong and why. When the exercise is over, they can all work together to make the shop a safe place to work again.
- Demonstrate the danger of a small, fast moving object. Have the students huddle in a tight group directly in front of you. Using a medicine ball and a bat, hit the ball directly at them. Then switch to a hardball—but don’t hit it! Your students should get the point.
- Demonstrate the average person’s reaction time in relation to the speed of a blade or cutter.
- Take your students out into the shop area and demonstrate mock accidents to show them what can go wrong if they neglect to follow the safety rules in the shop.
- Keep evidence of accidents and demonstrate or explain to students what went wrong at the time the accident occurred and the injuries suffered.

## Suggested Strategies (cont.)

### Student Participation

People generally remember more of what they learn if they are actively involved during the learning process. So, whenever possible, offer students an activity where they can actually do something to demonstrate safe work practices. The most obvious, of course, is to ask them to perform a new task modeling the safe work practices you have taught them. Other methods include:

- Ask students to research a certain aspect of safety in the shop area. Then ask them to present a mock demonstration of the correct and incorrect ways to perform the task and explain the consequences.
- For those who have a talent for art, you might suggest they research and design a poster about safety that will appeal to their age group.
- Following a simulated work accident, have students fill out an accident report and discuss as a group.
- Ask students to share with the class their own experiences of accidents that occurred because safety was not practiced.

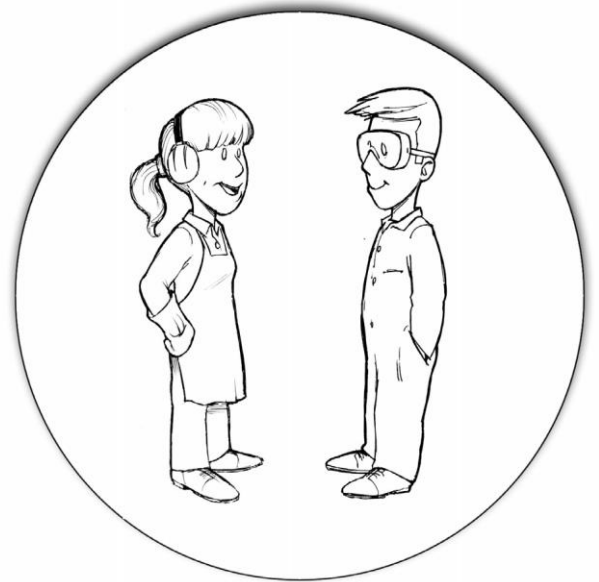

## Suggested Strategies (cont.)

The issue of safety in the workplace has necessitated the development of a number of initiatives to encourage people to think about and practice safe work habits on the job. Some of these same initiatives could be implemented into your shop program:

- Pledges – have students sign a pledge form or a statement of commitment stating that they are familiar with the safety practices and procedures required in the shop.
- Committee – have students form a safety committee to monitor the activities in the shop.
- Competitions – implement inter-class competitions for accident-free days.
- Bonus Marks/Awards – give bonus marks/awards to students who maintain good safety records.
- Operator’s Card – provide each student with a card identifying which machines they can work on independently based on having met the required safety standards.

### Testing for Comprehension

As an instructor, you must test to make certain that your students have learned the importance of safety in the shop area, and that they are willing and able to practice the safe work habits that you have taught them. Some methods of evaluating their knowledge include:

- Performance tests where each student must pass a written exam identifying how to perform certain skills or operate specific equipment safely.
- Demonstration tests where each student must demonstrate the ability to perform the skill or operate the equipment safely before you give them permission to work independently in that area.

#### **Scenario 2: Jointer Accident**

**Student A showed Student B how to use a table-mounted jointer. Student B engaged the equipment’s start mechanism causing severe injuries to the hand of Student A resulting in partial amputation to their fingers.**

**Safety tip: Students need to be properly instructed and tested on all equipment prior to use.**

## Assessment Tools

### Record Keeping

In order to qualify students to work with minimal supervision on shop equipment, you will need to keep accurate records to verify that they have met the necessary criteria:

- **Did they attend the demonstrations on how to use the equipment?**
- **Did they complete and pass the safety test?**
- **Did they attend/pass a make-up if they missed the demonstration or test?**
- **Did you observe the student the first time they used the machine?**

The importance of maintaining this information cannot be stressed enough. Not only will it give you some 'peace of mind' knowing who qualifies to use the equipment, but it will provide you with the required information should an issue of liability arise.

In BC, a student or their family has the right to make a claim for an injury that occurred during a school activity up until the student reaches the age of 21. **All class records must be kept for seven years; in the case of an accident, they must be kept for ten years.** As you will see in the sample case studies provided in this handbook, in a court of law, the shop teacher may be expected to identify the student's skill level and training up to the point when the accident occurred. Without accurate class records, your chances of remembering this information is poor.

### **Scenario 3: Circular Saw Accident**

**A student was using a circular saw and contacted the saw blade with their right hand. There was no safety guard over the blade and significant injuries to the student's thumb and fingers resulted in a permanent disability. If a safety guard had been in place, it would have been impossible for the accident to have occurred the way it did.**

**Safety tip: Equipment without safety guards should be withdrawn from use until proper safety guards are installed.**

## Assessing the Risks

Shop teachers have a duty to conduct risk assessments to ensure protection against hazards in the shops. Conducting risk assessments is fundamental to preventing and reducing injuries and diseases.

### What Does a Risk Assessment Involve?

Assessing the risks involves identifying the hazards that exist and assessing the impact of the identified hazards on those that work in the area. A hazard is a thing or condition that may expose a person to a risk of injury or occupational disease. Assessing the risk means determining the likelihood that the hazard may lead to injury and/or disease. In other words, determine if the risk is low, medium or high. For example, a tripping hazard is present when an extension cord is placed across an area in the shop. The risk, however, may be low or high dependent on a number of factors. The risk may be low if no one ever walks in that area. The risk may be high if any one of the following is present: the area is used frequently by students and/or teachers, the lighting in the area is poor, and/or there are no warning signs or devices to indicate there is a hazard.

### Controlling the Risks

Once hazards are identified and risks are assessed, the risks need to be controlled. To ensure protection against a hazard, a hierarchy of risk control planning is used within the health and safety professional community:

1. Reduce the risk
  - Can the task be avoided?
  - Can the hazardous part of the task be removed?
  - Can it be done in such a way that students are not exposed to the hazard?

## Assessing the Risks (cont.)

### 2. Substitute with something else to produce a less hazardous situation

- Can a different machine or tool be used?
- Can less hazardous materials or chemicals be substituted?
- Can different work practices be developed to reduce exposure to the hazard?

### 3. Implement an engineering control

- Can the layout arrangements, equipment, materials, or other aspects of the physical work environment be re-designed?
- Can the hazard be controlled at its source (e.g. local ventilation)?
- Can the hazard be enclosed (e.g. noise control)?
- Can a physical barrier be provided (e.g. guarding)?

### 4. Apply an administrative solution

- Can tasks be organized, scheduled and coordinated differently (e.g. two students do the lift instead of one)?
- Can the shop be reorganized to provide distance between the hazard and the students?
- Can tasks be scheduled to reduce the individual exposure to the hazard (e.g. providing regular breaks, rotating work assignments)?

### 5. Provide Personal Protective Equipment (PPE)

- PPE should only be used when the other four options discussed above have been considered and found to be impracticable.
- Is PPE provided?
- Are students trained in the proper use of PPE?
- Are students following safe work procedures when using PPE?

## Liability

The law places a very strict ‘duty of care’ upon School Districts and teachers with respect to students in shop classes. School Districts are required to provide safe equipment and teachers must provide proper instruction in the use of dangerous machinery. According to legal principles, the duty of care required is determined by the following factors:

1. The **probability** of an accident happening;
2. The **potential** severity of such an accident; and
3. The **costs** of reducing risk.

Judges have determined that there is a high probability of risk if safety instructions are not given clearly and carefully to students receiving instruction in the use of power tools and machinery. Consequently, if an accident happens and a student is injured, the courts may judge relatively minor omissions in instruction to be an act of negligence and find the teacher (and thus the School District, as employer) responsible, or partially responsible, for the student’s injuries.

### Vicarious Liability

Normally, it is the school board who will be held to be liable for the negligence of teachers, administrators, or other employees. This liability arises under the doctrine of vicarious liability which provides that an employer is liable for the torts committed by an employee while acting in the course of employment. The phrase ‘in the course of employment’ generally encompasses those authorized acts of an employee which are wrongful, and unauthorized ways of performing an authorized task. Therefore a board will not only be liable if a teacher is negligent in carrying out an assigned task, but may also be liable where the negligent acts occur during the course of unauthorized conduct. But see Beauporlant et al. v. Board of Trustees of Separate School Section No. 1 of Appley (1995) 4 D.L.R. 558, where the Court held that even though a school board is liable for the negligent acts of its teachers, such acts must fall within the ‘scope of employment.’ The court concluded that a teacher who gave students half a holiday for a field trip to a nearby town without obtaining consent from the school board, and who was negligent in arranging the type of transportation, exceeded his authority and there was no basis for assigning responsibility to the school board.

## Duty of Care

Historically, the courts have imposed a special duty of care on teachers and school districts commonly referred to as the rule of the careful parent. It was modified by a decision of the Supreme Court in Myers et al v. Peel County Board of Education. The court identified a number of factors which would be considered to determine if the standard of care had been met in a particular case:

1. The number of students being supervised at any given time;
2. The nature of the exercise of activity in progress;
3. The age and degree of skill and training which students may have received in connection with such activity;
4. The nature and condition of the equipment in use at the time;
5. The competency and capacity of the students involved; and
6. A host of other matters which may be widely varied but which, in a given case, may effect the application of the prudent parent standard to the conduct of the school authority in the circumstances.

### Safety

**Safety comes from man's mastery of his environment and himself. It is won by individual effort and group cooperation.**

**It can be achieved only by informed, alert, skillful people who respect themselves and have a regard for the welfare of others.**

– Author Unknown



## Safety in the Shop is Everyone's Business

The following is a list of responsibilities as adapted from the Workers' Compensation Board in their *WorkSafeBC Online* document, "Safety On the Job is Everyone's Business."

### Employer (*School District/Administrator*)

- Provide a safe environment
- Take action immediately when the worker or supervisor tells you about a potentially hazardous situation
- Initiate an immediate investigation into accidents
- Report serious staff accidents to WCB; Promptly report student accidents to the school district office and the Schools Protection Program
- Provide adequate First Aid facilities and services
- Provide personal protective equipment (PPE) where required

### Supervisor (*Technology Education Teacher*)

- Instruct students in safe work procedures
- Train students for all tasks assigned to them and check their progress
- Ensure that only authorized, adequately trained students operate tools and equipment
- Enforce safety regulations
- Identify students with problems such as drug & alcohol that could affect their safety and the safety of others; follow up with interviews and referrals where necessary.
- Formulate safety rules and inspect for hazards in your own area
- Keep records of safety tests
- Correct unsafe acts and conditions
- Complete a Schools Protection program incident report each time an accident occurs

### Employee (*Student*)

- Know and follow safe procedures affecting your work
- If you do not know, ask for training before you begin work
- Work safely and encourage your classmates to do the same
- Report any unsafe conditions to your teacher

**Note: Students are not employees and, therefore, if injured, are not entitled to Workers' Compensation Benefits.**

## Due Diligence

Due diligence requires taking all reasonable steps to protect workers from harm. 'All reasonable steps' is based on the level of judgment and care that a person would reasonably be expected to do under the circumstances. An organization that actively manages health and safety and takes all reasonable steps to protect workers from harm is being duly diligent.

Due diligence requires that you:

- Identify all workplace hazards
- Implement all necessary preventive measures
- Communicate appropriately to all necessary personnel

## Steps to Being Duly Diligent

1

### Be Aware

Ignorance is no defence.

2

### Be Objective

Identify issues for your workplace using appropriately knowledgeable people.

3

### Be Proactive

Develop a safety program that includes procedures, and practices to minimize risk from hazards. Communicate these practices and ensure all workers are trained.

An active safety management approach—one that demonstrates due diligence—ensures that workers are provided with valuable safety information, instruction and training.

## Technology Education (Shop) Teacher

### Duty of Care

The following are the **minimum** expectations that a teacher working in a school shop program will follow:

1. Have a basic **understanding** of the procedures and safety required when using tools and equipment.
2. Have a **process** that shows a **consistent** delivery for student safety in the shop.
3. Give sufficient **instruction** and training so students can be safe and successful working in the shop.
4. **Demonstrate** safe use of Machines and Tools to students.
5. **Administer** safety tests, ensure students make appropriate **corrections** if necessary, **and record** date and results.
6. Have students **demonstrate** using machinery for first time.

**Note:** Teachers can find more detailed information regarding due diligence and Shop teacher responsibilities in the previous version of *'Heads up for Safety'*- 2002.

## **Table of Contents:**

### **GENERAL SHOP**

General Shop Safety Rules .....	22
Workshop Safety.....	23
Portable Power Tools Safety.....	27
Combustibles and Toxic Substance Safety.....	29
Power Tools Safety.....	32
WHIMIS Safety.....	36
PPE.....	38

### **WOOD SHOP**

Wood Shop Safety .....	40
Hand Drill.....	45
Band Saw Safety.....	46
Jointer Safety.....	48
Thickness Planer Safety.....	50
Portable Circular Saw Safety.....	52
Radial Arm Saw Safety.....	54
Table Saw Safety.....	55
Wood Lathe Safety.....	57
Sliding Compound Mitre Saw Safety.....	59
Disk/Belt Sander Safety.....	61
CNC Wood Router Safety.....	63
Thickness Sander Safety.....	64
Edge Sander Safety.....	65
Spindle Sander Safety.....	66
Wood Router Safety .....	68
Drill Press (wood) Safety.....	70
Scroll Saw Safety.....	72

### **METAL SHOP**

Metal Shop Safety .....	75
Arc Welding Safety.....	80
Bench Grinder Safety.....	81
Sheet Metal Box & Pan Brake Safety.....	82
Horizontal Bandsaw Safety.....	83
Vertical Bandsaw Safety.....	84
Buffer/Wire Wheel Safety.....	86
Forge/Temper Safety.....	88
Foundry Safety.....	89
Metal Cut Off Saw Safety.....	91
Metal Lathe Safety.....	93
Oxy-Acetylene Safety.....	95

Plasma Torch Safety.....	97
Sand/Bead (Media) Blaster Safety.....	99
Milling Machine Safety.....	100
Powder Coating.....	102
MIG/TIG Safety.....	103
Spin Caster Safety.....	105
Jewelry Torch Safety.....	106
Solder Pencil/Iron Safety.....	107
Disk/Belt Sander Safety .....	109
Beverly Shear Safety.....	111
Squaring Foot Sheer Safety.....	112
Drill Press (metal) Safety.....	114
Spot Welder/Resistance Welder Safety.....	116
Right Angle Grinder Safety.....	117
CNC Plasma Cutter Safety.....	118
Kiln/Burnout Oven Safety.....	119
<b><u>AUTO SHOP</u></b>	
Automotive Shop Safety.....	121
Vehicle & Engine Safety.....	125
Air Tools .....	128
Battery Handling Safety.....	130
Engine Crane Safety.....	132
Engine Stand Safety.....	134
Brake Lathe.....	136
Jack & Jack Stand .....	138
Hoist Safety – 2 POST.....	140
Hoist Safety – 4 POST.....	141
Hydraulic press.....	143
Solvent Tank .....	144
Wheel Balancer Safety.....	145
Tire Machine.....	146
<b><u>MAKER</u></b>	
General Makerspace Rules.....	149
Soldering Iron .....	151
Etchant Tank.....	152
3D Printer Safety.....	153
Laser Engraver Safety.....	154
<b><u>APPENDIX I</u></b>	
Case Studies.....	155

# **GENERAL SHOP**

## General Shop Safety Rules

- 1) Operate machines **ONLY** with the instructor's permission and after you have received proper instruction.
- 2) Remove jewelry, eliminate loose clothing, hoods and drawstrings, ear buds/head phones and confine long hair when working in a shop environment.
- 3) Always use appropriate Personal Protective Equipment (PPE) while in the shop when working with power tools. Always wear safety glasses, or a face shield.
- 4) All accidents must be reported to the instructor immediately.
- 5) Don't use tools or equipment that are in any way defective/damaged. Tell the instructor immediately if the equipment doesn't look proper.
- 6) Damp, oily rags are a fire hazard. Place rags in the RED metal fireproof container.
- 7) Always use a hand brush to wipe away sawdust or scraps. Never use your hand.
- 8) The floor must be kept clean. Don't leave anything lying around that could be tripped on or slipped on.
- 9) Carry sharp or pointed tools with the edge or point held in your hand and pointing away from you. This will help prevent injury to others if someone bumps you or you trip.
- 10) Use ALL recommended guards and safety devices on the machinery as shown by your instructor.
- 11) Always unplug a tool or disconnect the circuit breaker to prevent accidental starting of the equipment when you are making changes to it.
- 12) Wait for a machine to come to a **COMPLETE** stop before leaving it.
- 13) No talking to others while operating a machine or talking to the operator.

## GENERAL WORKSHOP SAFETY

Topic	Notes	Student Information
<b>Accidents</b>	Make sure you have First Aid supplies on hand at all times, conduct accident/incident investigations and keep records.	<ul style="list-style-type: none"> <li>Immediately report all accidents or injuries so that proper treatment can be given and the dangers removed or dealt with</li> </ul>
<b>Behaviour</b>	Providing for the safety of the students in your care is your most important role. Expectations about student behaviour should be clearly defined, explained and enforced. Horseplay will not be tolerated.	<ul style="list-style-type: none"> <li>Workshops are hazardous environments; adopt a calm, careful attitude at all times</li> <li>Walk, don't run; avoid pushing or bumping</li> <li>Horseplay (e.g., throwing things) is not allowed</li> </ul>
<b>Clothing</b>	Expectations about student attire should be clearly defined, explained and enforced.	<ul style="list-style-type: none"> <li>Tuck in loose clothing, tie back long hair, remove loose jewelry</li> <li>Wear sturdy shoes, appropriate clothing for activity; wear protective gear when required</li> </ul>
<b>Emergencies</b>	Make sure you have adequate emergency equipment on hand at all times, and teach your students what to do if an emergency occurs.	<ul style="list-style-type: none"> <li>Know what to do in an emergency</li> <li>Be familiar with emergency equipment including fire extinguishers, power shut off buttons, fire blankets, and eye wash stations</li> </ul>
<b>Eye Protection</b>	Ensure eye protection is available and in good condition.	<ul style="list-style-type: none"> <li>Wear eye protection when required, e.g., when using power tools, or hammering metal, stone or other hard materials</li> </ul>
<b>Sharp Objects</b>		<ul style="list-style-type: none"> <li>Do not carry sharp objects such as nails, chisels, etc., in your pockets or mouth; carry them with the pointed end facing downward</li> </ul>



## GENERAL WORKSHOP SAFETY (cont.)

Topic	Notes	Student Information
<b>Housekeeping</b>	Develop, implement and oversee an effective 'clean up' routine.	<ul style="list-style-type: none"> <li>• Clutter poses unnecessary slipping and tripping hazards; keep the floor and work surfaces clean and clear</li> <li>• Tools, materials and projects should all be stored safely and securely</li> <li>• Aisles and exits should be unobstructed at all times; keep cupboard doors closed, unused vises closed, etc.</li> </ul>
<b>Mental Condition</b>	Do not assign students work if they will endanger self or others	<ul style="list-style-type: none"> <li>• Most accidents occur to people who are tired, rushed or under the influence of alcohol or drugs, so avoid working in these states</li> </ul>
<b>Personal Responsibilities</b>	<p>Encourage students to take responsibility for themselves and their classmates at all times.</p> <p>Encourage students to regularly conduct safety checks on themselves, their material and the tools.</p>	<ul style="list-style-type: none"> <li>• If you feel unsafe about a particular activity, consult with your instructor before proceeding</li> <li>• If you see something dangerous, report it so it can be fixed</li> <li>• Be aware of the risks your work may pose to others, especially when using equipment like arc welders, compressed air, and grinders</li> </ul>
<b>Compressed Air</b>		<ul style="list-style-type: none"> <li>• Compressed air should not be used to clean clothing except in carefully controlled circumstances (WCB regulation)</li> <li>• Compressed air should not be used for cleaning off equipment if someone could be exposed to the jet or to the material it expels (WCB regulation). Use vacuums to clean clothing and shop areas</li> </ul>

**GENERAL WORKSHOP SAFETY (cont.)**

Topic	Notes	Student Information
<b>Condition of Tools</b>	Remove all dull, broken and maladjusted tools from the workshop area until they have been repaired.	<ul style="list-style-type: none"> <li>• Only use tools that are in good working order</li> <li>• If a tool is dull, broken or out of adjustment, give it to your instructor or ask for permission to fix it</li> </ul>
<b>Material Handling</b>	If students are lifting heavy objects, give a separate lesson on proper lifting techniques.	<ul style="list-style-type: none"> <li>• Move heavy objects using proper lifting techniques</li> <li>• When moving heavy objects, be aware of others in the room</li> <li>• Make sure materials are safely and securely stored, if necessary, ask for help</li> </ul>
<b>Protect Your Hands</b>	Statistics identify that most injuries in school workshops occur to students' hands.	<ul style="list-style-type: none"> <li>• Keep your hands behind the blade on any cutting tool</li> <li>• Test tools for sharpness on wood or paper, not with your fingers</li> <li>• To test for heat, place your hand near, but not on, the object</li> </ul>
<b>Secure Your Work</b>		<ul style="list-style-type: none"> <li>• Make sure the piece you are working on is stable</li> <li>• Secure the piece you are working on by putting it in a vise or clamp on the workbench</li> <li>• Never hold stock with one hand while trying to cut, chisel or drill it with the other hand</li> </ul>
<b>Use Tools as Intended</b>	Emphasize the importance of using tools properly and set a good example.	<ul style="list-style-type: none"> <li>• Using tools improperly can lead to injury of self or damage to the tool, e.g., hammering with a wrench, prying with a chisel, using files without handles</li> </ul>

## General Shop Safety Test

Student Name: \_\_\_\_\_

Date: \_\_\_\_\_

	TRUE/FALSE	
	T	F
1. I can use ANY machine in the shop without receiving proper instruction on it		
2. Once you are finished using a machine, turn it off and walk away immediately		
3. If you injure yourself, tell the instructor immediately		
4. Carry sharp tools by the handle and the point facing up so you know where the sharp point always is.		
5. Throw damp, oily rags in the garbage just like everything else		
6. Safety guards ALWAYS need to be in place when using equipment		
7. If a tool looks broken or defective, you can try and see if it works before telling the instructor		
8. You need eye protection when working with power tools and machines		
9. Loose clothing and long hair are a safety hazard in the shop		
10. If you make a change to a power tool, just turn it off and make the change. You do not need to unplug it		
I have discussed shop safety with the instructor and understand that I need to be careful when working around power tools so nobody gets injured.  <b>Signed:</b> _____	<b>SCORE:</b> /	

## PORTABLE POWER TOOLS SAFETY

Topic	Information
<b>Damaged Power Cord</b>	Do not use tools if the power cord is damaged. The insulation should be intact and without tears, the ground connection should be working if the tool is designed with a ground, and the connections plug to wire and wire to tool should be solid. Fix or replace damaged cords
<b>Direction of the Tool and Material</b>	Understand which way the action of the tool will push the material and the tool itself. Usually they try to go in opposite directions. Power planers push the stock away and the tool towards the operator. Belt sanders do the opposite. Right angle grinders depend on which part of the wheel you grind with. The point is to make sure you know what is going to happen and are ready to control those forces. Hold that tool with a firm grip.
<b>Ear and Eye Protection</b>	Many portable power tools run at very high speeds and scream in operation. Wear hearing protection if the tool is noisy or you have to raise your voice to speak to others. Wear eye protection when using portable power tools.
<b>Path of the Tool</b>	Make sure the path of the tool is clear. Saw blades stick out the bottom of the stock. Will they cut anything unintentionally? Is the cutter on your router or power planer going to hit the top of the vice? When the drill bit breaks through, where is it going? Whatever tool you are using, make sure it will cut, drill or grind only what you want to cut, drill or grind. Make sure the cutting part is not going to come in contact with the power cord.
<b>Power Switch</b>	Check that the power switch is in the off position before plugging in any portable power tool.
<b>Secure Your Work</b>	Large machines stay in place while the material moves. With portable machines, the tool moves and the material is supposed to stay in place-make sure it does! Put the stock in a vice, clamp it to a work bench or wedge it in a corner, but don't try to hold a small piece of material in one hand while you approach it with a power tool held in the other.
<b>Unplug the Tool</b>	Unplug the tool whenever you are changing bits, replacing blades or fixing something on the tool. You could easily bump the trigger unintentionally while handling the tool. Keep the plug within your sight and control so that it doesn't get inadvertently plugged in while you are working on the tool.
<b>Cordless Tools</b>	Disconnect the battery when changing bits, replacing blades or fixing something on the tool.

## Portable Power Tool Safety Test

Student Name: \_\_\_\_\_

Date: \_\_\_\_\_

	TRUE/FALSE	
1. Always wear safety glasses when using power tools	T	F
2. Hearing protection is not recommended on any power tool	T	F
3. You should unplug a tool when changing bits or blades	T	F
4. Cordless tools cannot hurt you because they are not very powerful	T	F
5. The teacher should be told of any damaged tools	T	F
6. Check tool switch is off before plugging in a power tool	T	F
7. Clamp materials down to secure work from moving	T	F
8. Check tool path before starting to drill or cut	T	F
I have discussed shop safety with the instructor and understand that I need to be careful when working around power tools so nobody gets injured.	<b>SCORE:</b> /	
<b>Signed:</b> _____		

## COMBUSTIBLES AND TOXIC SUBSTANCES

Topic	Notes	Student Information
<b>Combustibles and Toxic Substances</b>	Monitor the use of combustibles and toxic substances and provide adequate storage. Explain and follow procedures for safe handling, use, storage, and disposal, including emergency and spill cleanup procedures.	<ul style="list-style-type: none"> <li>Note that many industrial supplies are flammable, explosive or subject to spontaneous combustion</li> <li>Store combustible supplies and waste in fire safe containers</li> </ul>
<b>Corrosives</b>	Acids and caustics can burn skin and eyes causing permanent damage and corrode metals. Use protective equipment: goggles, face shield if needed, gloves, shop coat and apron. Emergency eyewash and skin washing facilities are required.	<ul style="list-style-type: none"> <li>Acids and caustics can burn skin and eyes causing permanent damage; they can also corrode metals</li> <li>Wear goggles, gloves, and protective clothing</li> </ul>
<b>Flammables and Combustibles</b>	<p>Monitor the use of flammables and combustibles and provide adequate storage.</p> <p>Supply only the minimum quantity required for daily use. Explain and follow procedures for safe handling, use, storage and disposal, including emergency and spill clean up procedures.</p>	<ul style="list-style-type: none"> <li>Note that many industrial supplies are flammable, explosive or subject to spontaneous combustion</li> <li>Store combustible supplies and waste in fire safe, closed containers</li> <li>Keep flammables and combustibles away from ignition sources</li> </ul>

**COMBUSTIBLES AND TOXIC SUBSTANCES (cont.)**

<b>Topic</b>	<b>Notes</b>	<b>Student Information</b>
<b>Chemicals / Hazardous Substances</b>	<p>Explain the Workplace Hazardous Materials Information System (WHMIS) including safe use, storage, handling, supplier labels, workplace labels, Material Safety Data Sheets (MSDS), disposal and emergency and spill clean up procedures for products used in shops.</p> <p>Label container if you transfer product from original (e.g., when transferring product into another container).</p> <p>See WCB publication ‘WHMIS at Work’ for more information.</p>	<ul style="list-style-type: none"> <li>• Follow procedures for safe handling, use, storage, and disposal, including emergency procedures and spill clean up</li> <li>• Label containers if you transfer product from original</li> <li>• Know where to find Material Safety Data Sheets (MSDS)</li> <li>• Be able to answer the following questions for each product used: <ul style="list-style-type: none"> <li>○ What are the hazards of the product you are using?</li> <li>○ How do you protect yourself from the hazards of the product?</li> <li>○ What would you do if an emergency occurred?</li> <li>○ Where can you find out more information about the product you are using?</li> </ul> </li> </ul>
<b>Hazardous Waste</b>	<p>Ensure procedures are in place and explain handling and disposing of hazardous waste (e.g., antifreeze, used oil)</p>	<ul style="list-style-type: none"> <li>• Follow procedures for handling and disposing of hazardous waste</li> </ul>
<b>Wood Dust</b>	<p>Some wood dusts cause allergies, for example: oak, mahogany, Western red cedar, and California redwood. Avoid using these woods.</p>	<ul style="list-style-type: none"> <li>• Some wood dusts cause allergies (e.g., oak, mahogany, Western red cedar, California redwood).</li> </ul>

**COMBUSTIBLES AND TOXIC SUBSTANCES (cont.)**

Topic	Notes	Student Information
<b>Substances Under Pressure</b> (e.g., compressed gas cylinders)	<p>Protect substances under pressure from sparks, flames, heat, physical damage, electrical contact, and corrosion.</p> <p>Explain procedures for safe handling, use, storage and emergency procedures.</p> <p>Ensure:</p> <ul style="list-style-type: none"> <li>• pressure testing is current</li> <li>• cylinder indicates type of gas</li> <li>• cylinders are secured to prevent falling or rolling and kept upright</li> <li>• valves are kept closed when empty or not in use</li> <li>• flashback arresters and uniflow valves are used</li> <li>• the valve cover is in position when not connected for use or guarded</li> <li>• regulators are regularly maintained (clean, no broken glass, missing screws or grease)</li> <li>• procedures for safe use are followed</li> </ul>	<ul style="list-style-type: none"> <li>• Cylinders can explode if dropped or heated. Follow procedures for safe use</li> <li>• Keep cylinders away from ignition sources</li> </ul>
<b>Poisons</b>	<p>Poisons can be ingested, inhaled or absorbed through skin, therefore it is important to wear appropriate protective equipment.</p> <p>Avoid accidental poisoning by labelling containers (e.g., when transferring product into another container).</p>	<ul style="list-style-type: none"> <li>• Follow procedures for safe use</li> <li>• Label containers if you transfer product from original</li> </ul>



## POWER TOOLS SAFETY

Topic	Notes	Student Information
<b>Authorization</b>	<p>How strict you are about students asking for permission to use power tools depends on a number of variables: age and experience of the student, power tool in question, and the operation to be performed. The safest approach is to have them ask you for permission each time they want to use a power tool. Students should not run tools unless they are trained or under direct supervision.</p>	<ul style="list-style-type: none"> <li>You must have authorization before using any power tools</li> </ul>
<b>Condition of Tools</b>	<p>Remove broken machines and damaged electrical cords from the workshop until they have been adequately repaired.</p> <p>Make sure all guards are in place and in good working order. In unusual circumstances where a guard cannot be used, the instructor must be present.</p>	<ul style="list-style-type: none"> <li>Only use tools that are in good operating condition</li> <li>Check out any unusual vibrations or noises before using a machine</li> </ul>
<b>Personal Protective Equipment</b>	<p>High noise areas should be identified and signs posted to require hearing protection. Eye and hearing protection should be required in all shops when conditions warrant it.</p>	<ul style="list-style-type: none"> <li>Wear hearing protection when operating all power tools</li> <li>Long hair must be contained before using any power equipment</li> </ul>
<b>Know How Your Machine Works</b>		<ul style="list-style-type: none"> <li>Know which direction your tool will go when you run material through it and which way the material will go; in other words, make sure you know what is going to happen before you operate a machine so you can be ready to control those forces</li> </ul>

**POWER TOOLS SAFETY (cont.)**

<b>Topic</b>	<b>Notes</b>	<b>Student Information</b>
<b>Lockout</b>	<p>Conduct specific lockout training. Refer to Occupational Health and Safety Regulation, Book 2, Part 10, for industrial lockout procedures. If the unexpected energization or startup of machinery or equipment, or the unexpected release of an energy source could cause injury, the energy source must be isolated and effectively controlled.</p> <p>Post written lockout procedures. Refer to WCB publication on lockout for more information.</p>	<ul style="list-style-type: none"> <li>When doing any maintenance work on a power tool, isolate the source of power (unplug it, switch the breaker off and follow written lockout procedures)</li> </ul>
<b>Power Cord Damage</b>		<ul style="list-style-type: none"> <li>Check all power cords daily for tears or cuts in the insulation, loose connections (plug to wire, wire to tool) and poor ground connections</li> </ul>
<b>Operator</b>		<ul style="list-style-type: none"> <li>The power tool operator must be qualified to use the tool</li> <li>The machine operator must concentrate on the task at hand</li> <li>Avoid distracting, bumping or rushing anyone using a machine</li> </ul>
<b>Secure Your Work</b>		<ul style="list-style-type: none"> <li>When working with portable power tools, make sure the material stays in place—put stock in a vice or clamp it to a workbench before approaching it with a power tool</li> <li>When operating a power tool, maintain a firm grip at all times</li> </ul>

**POWER TOOLS SAFETY (cont.)**

<b>Topic</b>	<b>Notes</b>	<b>Student Information</b>
<b>Path of the Tool</b>		<ul style="list-style-type: none"> <li>• Whatever tool you are using, make sure it will cut, drill or grind only what you want to cut, drill or grind—you do not want the saw blade sticking out the bottom of the stock, the cutter hitting the top of a vise, or the drill bit breaking through the stock</li> <li>• Be aware of the cutting path of the tool—keep your hands away from this area</li> <li>• Make sure the cutting part is not going to come in contact with the power cord</li> </ul>
<b>Start-up</b>		<ul style="list-style-type: none"> <li>• Check to ensure that all guards and safety devices are in place and functioning properly</li> <li>• Check to make sure the power switch is in the off position before plugging in a portable power tool</li> <li>• Only the operator is to turn the tool on</li> </ul>
<b>Stay Beside Running Power Tools</b>		<ul style="list-style-type: none"> <li>• Do not walk away from a machine you have been using until it comes to a complete stop—it takes only a few seconds for a power tool to ‘wind down’ after it has been shut off</li> </ul>
<b>Stop to Make Adjustments</b>	Adjustments should never be made to a power tool while it is running. The operator’s full attention should be on the cutter or active part of the machine.	<ul style="list-style-type: none"> <li>• Always unplug or lockout the tool before making any adjustments or changing settings where there is a danger of being injured in the event of a startup of the tool</li> </ul>

## Power Tools Safety Test

Student Name: \_\_\_\_\_ Date: \_\_\_\_\_

	TRUE/FALSE	
1. Always wear safety glasses when using power tools	T	F
2. You only need to ask instructor permission the first time you use a power tool	T	F
3. When changing blades or drill bits, always unplug or disconnect power	T	F
4. Loose hair and clothing should be tied back	T	F
5. A good way to get someone's attention when they are using a power tool is to bump or tap them	T	F
6. You never need to wear hearing protection in the shop because it is a school facility	T	F
7. Be aware of the tool path, so check under the material you are drilling or cutting to make sure only your project has material removed	T	F
8. Guards are not necessary if you know how to use a machine	T	F
9. Always unplug or lockout a tool before making adjustments	T	F
10. Wait until a machine stops before walking away	T	F
I have discussed shop safety with the instructor and understand that I need to be careful when working around power tools so nobody gets injured.  Signed: _____	SCORE: /	









## WORKPLACE HAZARDOUS MATERIALS INFORMATION SYSTEM (WHMIS) SAFETY

Topic	Notes	Student Information
<b>Identification/ Classification</b>	<p>Explain how being informed about hazardous material can save your life.</p> <p>Information is given to us in three ways: labels, MSDS, and training.</p>	<ul style="list-style-type: none"> <li>• Check with the teacher before using any substance that may be harmful</li> <li>• If in doubt ask</li> <li>• You must familiarize yourself in how things can harm you</li> </ul>
<b>Labels and Material Safety Data Sheets (MSDS)</b>	<p>Explain the types of labels and what information is on each.</p> <p>Explain what MSDS are and what information is found in them. Show the students where they are kept and how to find the proper MSDS for each product.</p>	<ul style="list-style-type: none"> <li>• Always read the label and the MSDS, and follow the safe handling procedures before you use any product for the first time or cannot remember how to use it correctly</li> </ul>
<b>Handling</b>		<ul style="list-style-type: none"> <li>• Always use the proper safety equipment and procedures</li> <li>• Know where all the protective equipment is kept (respirators, dust mask, gloves, face shields, etc.)</li> </ul>

## WORKPLACE HAZARDOUS MATERIALS INFORMATION SYSTEM (WHMIS) SAFETY (cont.)

Topic	Notes	Student Information
<b>Storage and Disposal</b>	<p>Have the class do an inventory of all controlled products, either as individuals, pairs or in small groups. On their inventory list, have them explain:</p> <ul style="list-style-type: none"> <li>- where and how it is stored,</li> <li>- whether or not it has an MSDS</li> <li>- whether or not it is properly labeled</li> <li>- how to dispose of it</li> </ul>	<ul style="list-style-type: none"> <li>• Make sure you find all the controlled products in the shop; know where you can get rid of them safely and correctly</li> </ul>
	<p>At the same time it is a good idea to have the class write a report explaining emergency evacuation procedures and map out the shop showing the fire alarm pulls, fire extinguishers, eye wash station location and first aid station location.</p>	

**PERSONAL PROTECTIVE EQUIPMENT (PPE)**

PPE	STANDARD	APPROPRIATE	INAPPROPRIATE
<p><b>EYE PROTECTION:</b> protects against impact, splash, visible and invisible light rays</p>	<p>Must be marked with CSA or ANSI Z87 markings.</p>		
<p><b>EYE PROTECTION FOR WELDING</b></p>	<p>Must be marked with CSA or ANSI Z87 markings.</p> <p>Lens shade number should be appropriate for the type of welding and the current levels.</p>		
<p><b>HEARING PROTECTION</b></p>	<p>Must be worn in loud environments</p>		
<p><b>FOOTWEAR</b></p>	<p>Closed toed shoes must be worn in all shop areas</p>		
<p><b>CLOTHING</b></p>	<p>Don't wear shorts or loose clothing when operating power tools. Roll up long sleeves and tuck drawstrings in</p>		

# WOODSHOP



## WOOD SHOP SAFETY

Topic	Notes	Student Information
<b>Band saw</b>	<p>Sometimes students can ‘hear’ if they are overloading the saw.</p> <p>Many accidents occur as the blade comes out at the end of the cut. Explain why the blade may come off.</p> <p>The need for relief cuts depends on the width of the blade.</p> <p>Don’t leave the machine while the blade is still in motion.</p> <p>Eye protection is required. Hearing protection is recommended.</p>	<ul style="list-style-type: none"> <li>• Set the upper guide and blade guard so it is just above the stock. Set the upper guide within 3mm (1/8”) of the stock</li> <li>• First option—use a push stick</li> <li>• Keep your fingers at least 5cm (2”) away from blade</li> <li>• Feed stock with light pressure, especially towards the end of the cut; avoid excessive twisting of the blade</li> <li>• Plan your work to avoid backing out of long cuts</li> <li>• Use relief cuts on sharp corners</li> <li>• Never cut round or irregular stock unless it is held in a jig of some sort to stabilize it</li> <li>• If the blade breaks, turn off the saw and inform your teacher</li> <li>• Do not stand to the right of the band saw when someone else is using it (if the blade breaks, it may flip out to the right)</li> <li>• Eye and hearing protection are required</li> </ul>

**WOOD SHOP SAFETY (cont.)**

Topic	Notes	Student Information
<b>Electric Hand Drill</b>	Eye protection is required.	<ul style="list-style-type: none"> <li>• Secure the stock; be especially careful with small pieces</li> <li>• Centre punch metals before drilling</li> <li>• Make sure the bit is tight in the chuck</li> <li>• Be especially careful with long hair that can get caught in the chuck or drawn into the motor vents</li> <li>• Maintain a good grip on the drill, especially as the bit breaks through the back of your stock</li> <li>• Keep cord away from drill area</li> <li>• Eye protection is required</li> </ul>
<b>Jointer</b>	<p>Most jointer accidents are caused by “trying to mill stock that is too small.”</p> <p>Open jackets, untucked shirts and loose cuffs are especially dangerous on the jointer.</p> <p>Eye protection is required, hearing protection recommended.</p>	<ul style="list-style-type: none"> <li>• After set up, ensure that all guards are in place and functional before turning on the jointer</li> <li>• Minimum length of stock: 300mm (12”)</li> <li>• Maximum depth of cut when edge jointing: 3mm (1/8”); when surface jointing: 1.5mm (1/16”)</li> <li>• Joint with the grain</li> <li>• Beware of staples, grit or other debris in the wood, as well as loose knots and severe checks</li> <li>• Step hands over cutter head</li> <li>• Use a push stick if the stock is lower than the fence</li> <li>• Never change the depth of the outfeed table</li> <li>• Eye and hearing protection are required</li> </ul>

**WOOD SHOP SAFETY (cont.)**

Topic	Notes	Student Information
<b>Planer</b>	<p>Never allow students to use the planer without the dust cover in place and the cutter head fully protected.</p> <p>Keep the rollers and pressure boards well-adjusted to provide smooth operation and prevent kickback. An accident is more likely if students have to struggle to get wood through the planer.</p> <p>Eye protection is required, hearing protection recommended.</p>	<ul style="list-style-type: none"> <li>• Minimum length of stock: 300mm (12"); - Maximum depth of cut: 3mm (1/8")</li> <li>• Stand to the side in case of kickback</li> <li>• Never look into a running planer</li> <li>• Never brush shavings off the table unless the planer is at a full stop; always use a brush to remove the shavings</li> <li>• Beware of staples, grit or other debris in the wood, as well as loose knots and severe checks</li> <li>• Beware of pinching your fingers or clothes between the stock and the table</li> <li>• Use a backing board when planing stock less than 10 cm (4" thick)</li> <li>• If your wood gets stuck, disengage the clutch and turn off the planer. Do not use your hand to clear the blockage—ask your instructor for assistance</li> <li>• Eye protection is required</li> </ul>

**WOOD SHOP SAFETY (cont.)**

Topic	Notes	Student Information
<b>Portable Circular Saw</b>	<p>The most frequent mishaps when using portable circular saws involve kickback, the blade getting pinched, or the blade guard not returning properly.</p> <p>Eye and hearing protection are required.</p>	<ul style="list-style-type: none"> <li>• Make sure your stock is stable; put it in a vice or clamp, if necessary</li> <li>• Position stock so that it will not pinch the blade as the cut proceeds</li> <li>• Never use the saw if the blade guard is sticking</li> <li>• Make sure the line of cut is clear underneath</li> <li>• The blade must be clear of the stock before the saw is turned on</li> <li>• Keep a firm grip on the saw as a pinch or bind will thrust it back towards the operator</li> <li>• Eye and hearing protection are required</li> </ul>
<b>Router</b>	<p>Routers are very noisy, so wear hearing protection.</p> <p>Suggest students check each setup using scrap wood.</p> <p>Eye and hearing protection are required.</p>	<ul style="list-style-type: none"> <li>• Unplug the router to change bits; put at least 15mm (1/2") inside the collet</li> <li>• Check that the switch is off before plugging in the router</li> <li>• Secure stock</li> <li>• Hold router firmly with two hands, and make sure the cord stays clear</li> <li>• Ensure the bit is clear of the stock before turning on the router</li> <li>• For best control, cut against the rotation of the bit</li> <li>• Make sure the bit has stopped rotating before putting the router down</li> </ul>

**WOOD SHOP SAFETY (cont.)**

Topic	Notes	Student Information
<b>Radial Arm Saw</b>	<p>Because the blade can pull itself forward, the area in front of the blade is always dangerous and hands should be kept clear. Consider painting this danger zone on the saw table.</p> <p>Rip cutting is hazardous on the radial arm saw. Do not rip with Radial Arm saw</p> <p>Eye protection is required.</p> <p>The Radial Arm saw has been removed from most high school shops. Recommended to use Mitre Saw instead.</p>	<ul style="list-style-type: none"> <li>• Minimum length, 300mm (12") supported by a fence</li> <li>• Make sure blade guard is in place and working properly</li> <li>• Make sure all stock is stable and well supported</li> <li>• Keep hands 150mm (6") on either side of the blade; push small scraps clear with another piece of wood</li> <li>• Check wood for knots and non-wood material such as gravel, nails, etc.</li> <li>• Anticipate a tendency of the saw to pull itself into the cut</li> <li>• When finished, lock the carriage behind the fence</li> <li>• Never cross your arms when using the radial arm saw</li> <li>• Do not cut round or irregular stock unless it is carefully secured</li> <li>• Support the ends of long boards</li> <li>• If a stop is being used, hold the wood against the fence between the stop and the blade</li> <li>• Eye protection is required</li> </ul>
<b>Compound Mitre Saw (sliding)</b>	<p>Always secure the wood against the fence and push the saw towards the fence when cutting.</p> <p>If the wood is warped, the Bow goes out and the Cup goes up.</p>	<ul style="list-style-type: none"> <li>• Use right hand on the trigger</li> <li>• Keep hands 150mm (6") away from the blade</li> <li>• Always secure wood against the fence</li> <li>• Push the saw towards the fence when cutting</li> <li>• Only use for crosscutting</li> <li>• If wood is warped, the bow goes out and the cup goes up</li> <li>• Eye protection is required</li> </ul>

## HAND DRILL

A drill is a tool fitted with a cutting tool attachment or driving tool attachment, usually a drill bit or driver bit, used for boring holes in various materials or fastening various materials together. The attachment is gripped by a **chuck** at one end of the drill and rotated while pressed against the target material.

### Important Parts:

- Drill chuck
- Trigger
- Speed control
- Power cord/Battery

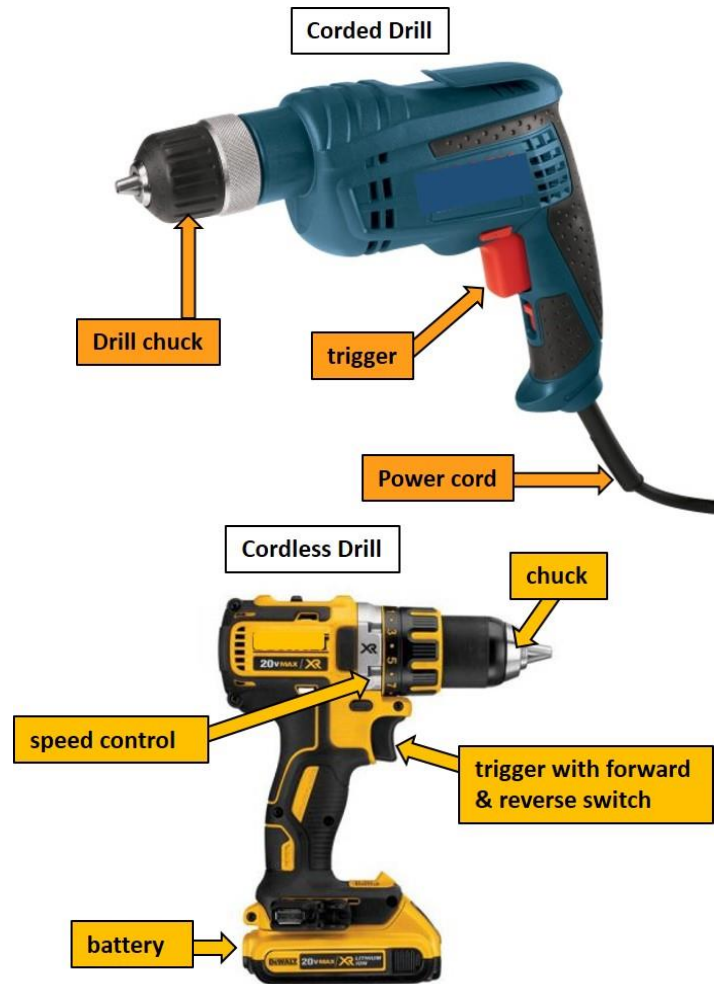

## SAFETY PROCEDURES

- Wear approved eye protection.
- Secure your stock before drilling. Large pieces may be stable on their own, but smaller pieces should be held in a vice. If there is any chance that the stock could catch on the bit and spin around, secure it in a vice or clamp. Keep the cord away from the drilling area.
- Centre punch metals before drilling. A small dimple made with a punch will keep the bit in place.
- Tie long hair back. Bending over your work or lifting the drill in the air are perfect opportunities for the electric hand drill to grab your hair.
- Make sure the bit is properly sharpened, and straight and tight in the chuck.
- Large drills are powerful enough to break your arm, so make sure you have a good grip on the drill and be prepared to hold it if it kicks back, especially as the bit passes through the far side of a piece of material.

## BAND SAW (WOOD)

A saw in which the blade is a continuous band of metal that moves vertically through the material. Only one side of the blade band has teeth. Keeps the blade location stationary while the material is moved through the blade.

### Important parts:

- Blade
- Guard
- Mitre slot
- Upper roller bearing
- Lower roller bearing
- Table tilt knob

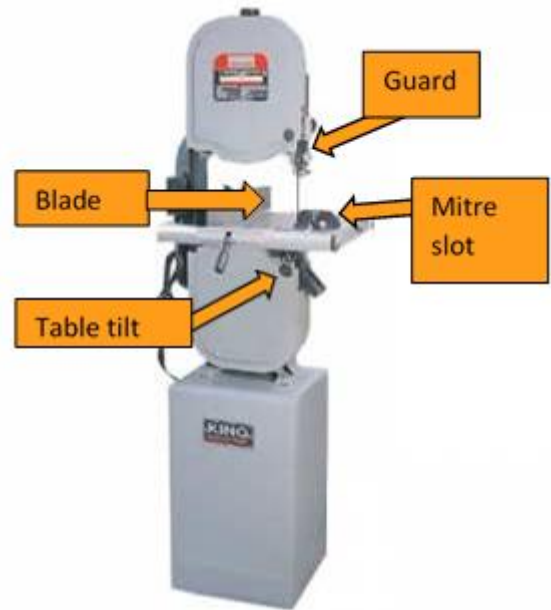

## SAFETY PROCEDURES

- Wear approved eye protection and hearing protection. Ensure long hair is tied back, all jewelry is removed, and closed toed shoes are worn.
- While cutting and keep your fingers at least 5cm away from the blade at all times.
- Set the upper guide and blade guard so they are just above the stock. This guards the blade and helps to keep the cut straight. The upper guide should be within 3mm of the wood.
- Always feed the stock with light pressure and avoid excessive twisting of the blade. If you push too hard or twist too much, you will hear the saw slow down. This is your cue to lighten up. Too much pressure or twisting can break the blade. Use even less pressure as you near the end of a cut because the blade will come out the last millimeter or so.
- If you have several cuts to make, plan your work so you can proceed in a sensible order. Never back out of long, curved cuts.
- Use relief cuts on sharp corners. Thinner blades can cut sharper corners without relief cuts.
- Round or irregular shaped wood presents special dangers because the force of the blade can twist it out of your control. Never cut round or odd shaped pieces unless you use a jig to stabilize them.
- If the blade breaks, turn off the machine and tell your teacher.
- Do not stand to the right of the band saw while someone else is using it. If the blade breaks, it might flip out in that direction.

## Vertical and Horizontal Bandsaw Safety Test

Student Name: \_\_\_\_\_

Date: \_\_\_\_\_

	TRUE/FALSE	
1. Always wear safety glasses on a bandsaw	<b>T</b>	<b>F</b>
2. If the blade breaks turn off the machine and tell the teacher	<b>T</b>	<b>F</b>
3. You can back out of long curved cuts with the machine still on	<b>T</b>	<b>F</b>
4. Make adjustments to the machine while it is cutting	<b>T</b>	<b>F</b>
5. Ensure your fingers are at least 2" away from the blade	<b>T</b>	<b>F</b>
6. The vertical bandsaw guide should be less than ¼" above stock	<b>T</b>	<b>F</b>
7. Horizontal bandsaw hydraulic arm speed should always be the same	<b>T</b>	<b>F</b>
8. Guards can be removed if not in working order	<b>T</b>	<b>F</b>
9. Always clamp materials when using horizontal bandsaw	<b>T</b>	<b>F</b>
10. Ask teacher permission before using	<b>T</b>	<b>F</b>
I have discussed shop safety with the instructor and understand that I need to be careful when working around power tools so nobody gets injured.  <b>Signed:</b> _____	<b>SCORE:</b> /	



## JOINTER

A jointer is used to create smooth, flat surfaces along the edges of a piece of wood.

### Important parts:

- Outfeed table
- Infeed table
- Cutter head
- Safety guard
- Fence

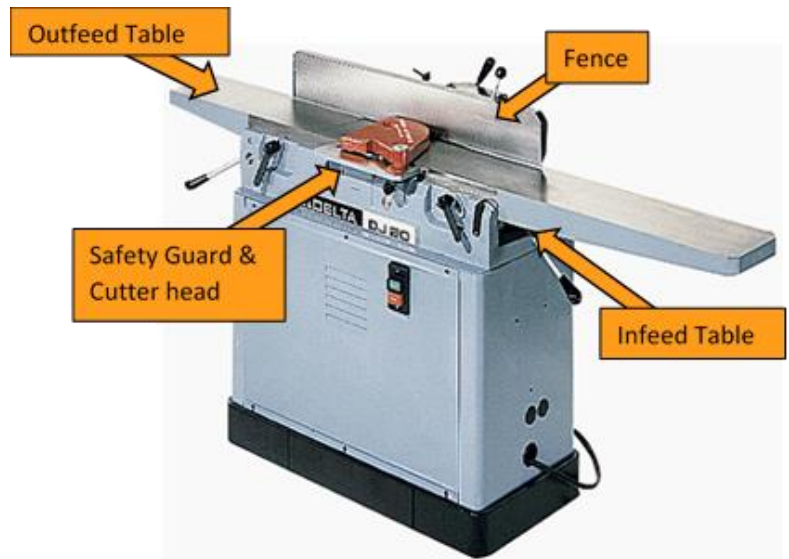

## SAFETY PROCEDURES

- Wear approved eye protection. Ensure long hair is tied back, all jewelry is removed, and that you are wearing closed toed shoes. Approved hearing protection is also recommended when using this machine.
- After set up, ensure that all guards are in place and functional before turning on the jointer.
- Most jointer accidents are caused by trying to joint wood that is too small-the wood flips up and back, often breaking the operator's thumb. Never joint stock that is less than 300mm long.
- On the jointer, you push the wood through the cut. If you try to cut too much, a kickback is likely to result. The maximum depth of cut when jointing an edge is 3mm. Maximum depth of the cut when jointing a surface (anything wider than 50mm) is 1.5mm.
- Always joint with the grain. This will give you a smoother cut and a better finish.
- Check your stock for staples, grit or other junk in the wood, and also look for loose knots and severe checks. Defects in the wood could damage the machine and cause kickback.
- Step your hands past the cutter head. If the wood were to kick out when your hand was above the cutter, your hand would drop onto the knives.
- You must use a push stick if the stock you are jointing is lower than the fence. It is hard to get a good grip on wood below the fence.
- Don't change the depth of the outfeed table. Adjustments must be made by a qualified person. Your teacher probably spent hours getting it just right and the setting is critical. If you change it, you will mess up your cut and create a hazard.

## Jointer Safety Test

Student Name: \_\_\_\_\_

Date: \_\_\_\_\_

	TRUE/FALSE	
1. Eye and hearing protection is only recommend and is up to the operator to decide if it is needed.	<b>T</b>	<b>F</b>
2. The shortest board that can be jointed on the jointer is 305mm (12 inches).	<b>T</b>	<b>F</b>
3. Fingers should never pass DIRECTLY over the revolving cutter blades.	<b>T</b>	<b>F</b>
4. After set up, ensure that all guards are in place and functional before turning on the jointer.	<b>T</b>	<b>F</b>
5. When jointing, keep the board in firm contact with the table and fence.	<b>T</b>	<b>F</b>
6. Always joint a board in the direction of the grain.	<b>T</b>	<b>F</b>
7. If the wood is below the level of the fence, push sticks MUST be used.	<b>T</b>	<b>F</b>
8. The OUTFEED table can be adjusted to change the amount of wood cut.	<b>T</b>	<b>F</b>
9. Joint ONLY one side and one edge of the board on the Jointer.	<b>T</b>	<b>F</b>
10. The wood to be jointed must be in good condition, with no glue, paint, hardware or other materials.	<b>T</b>	<b>F</b>
11. Joint the END GRAIN of a board if the saw has left a poor finish.	<b>T</b>	<b>F</b>
I have discussed shop safety with the instructor and understand that I need to be careful when working around power tools so nobody gets injured. <b>Signed:</b> _____	<b>SCORE:</b> /	

## THICKNESS PLANER

The thickness planer is a woodworking machine used to trim boards to a consistent thickness throughout their length and flat on both surfaces.

### Important parts:

- Infeed table
- Dust collection
- Table height adjustment
- Cutter head
- Feed rollers

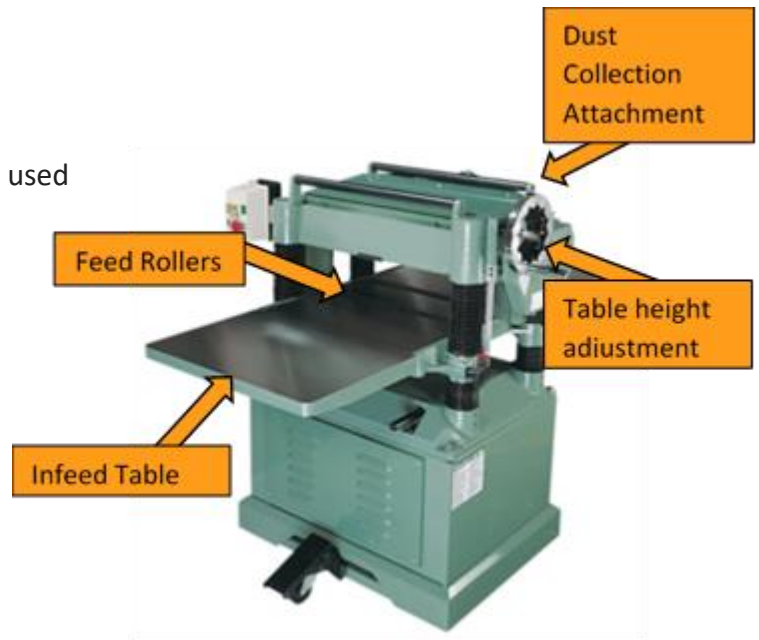

## SAFETY PROCEDURES

- Wear approved eye protection. Ensure long hair is tied back, all jewelry is removed, and that you are wearing closed toed shoes. Approved hearing protection is also recommended when using this piece of machinery.
- After set up, ensure all guards are in place and functional before turning on the planer.
- Never plane stock that is less than 300mm long. Short stock can get hung up between the power rollers inside the planer.
- Most planers have a shear pin that will break if the machine is overloaded. This protects more expensive machine parts from damage. Do not plane more than 3mm per pass.
- As with many power tools, wood can kick back out of the planer. Stand to the side so you won't get 'kicked' if the wood does shoot out. Never look into a running planer.
- Sometimes, if the vacuum system is plugged, shavings build up on the table of the planer. Never brush them off the table with your hand. If you need to clear the table, you should shut the planer off, wait for it to stop and use a brush.
- Check your stock for staples, grit or other junk in the wood, and also look for loose knots and severe checks. Defects in the wood could damage the machine and cause kickback.
- The rollers on this machine push the wood down against the table, hard. Tuck all loose clothing in and don't get your fingers pinched between the wood and the table.
- You can plane really thin wood but, because it has a tendency to flex under the rollers, it is recommended that you use a backing board when planing stock that is less than 10mm thick.
- If your wood gets stuck, disengage the clutch and turn off the planer. Do not use your hand to clear the blockage—ask your instructor for assistance.

## Thickness Planer Safety Test

Student Name: \_\_\_\_\_

Date: \_\_\_\_\_

	TRUE/FALSE	
1. The planer produces very little sound and does not require hearing protection.	<b>T</b>	<b>F</b>
2. The main purpose of the planer is to make two surfaces of the wood parallel.	<b>T</b>	<b>F</b>
3. Set the depth of cut on the planer by the wood touching the feed rolls.	<b>T</b>	<b>F</b>
4. It is acceptable to plane wood with excess glue on the surface because it will NOT dull the cutters.	<b>T</b>	<b>F</b>
5. The jointed face side of a board goes UP when planing.	<b>T</b>	<b>F</b>
6. Wood being cut in the planer must be at least 305 mm (12 inches) long.	<b>T</b>	<b>F</b>
7. Hands must be kept away from the infeed and outfeed rolls when the planer is running.	<b>T</b>	<b>F</b>
8. If the wood jams in the planer, look into the machine to find the problem.	<b>T</b>	<b>F</b>
9. Feed boards one at a time through the planer.	<b>T</b>	<b>F</b>
10. Eye protection is necessary when operating the planer.	<b>T</b>	<b>F</b>
11. It is acceptable to plane ACROSS the grain for a smooth finish.	<b>T</b>	<b>F</b>
12. "Walk" boards hand over hand instead of sliding them through your hands to prevent splinters	<b>T</b>	<b>F</b>
I have discussed shop safety with the instructor and understand that I need to be careful when working around power tools so nobody gets injured. <b>Signed:</b> _____	<b>SCORE:</b> /	

## PORTABLE CIRCULAR SAW

A circular saw is a power-saw using a toothed or abrasive disc or blade to cut different materials using a rotary motion spinning around an arbor.

### Important parts:

- Handle
- Power cord
- Blade
- Guard
- Base plate
- Trigger
- Front grip

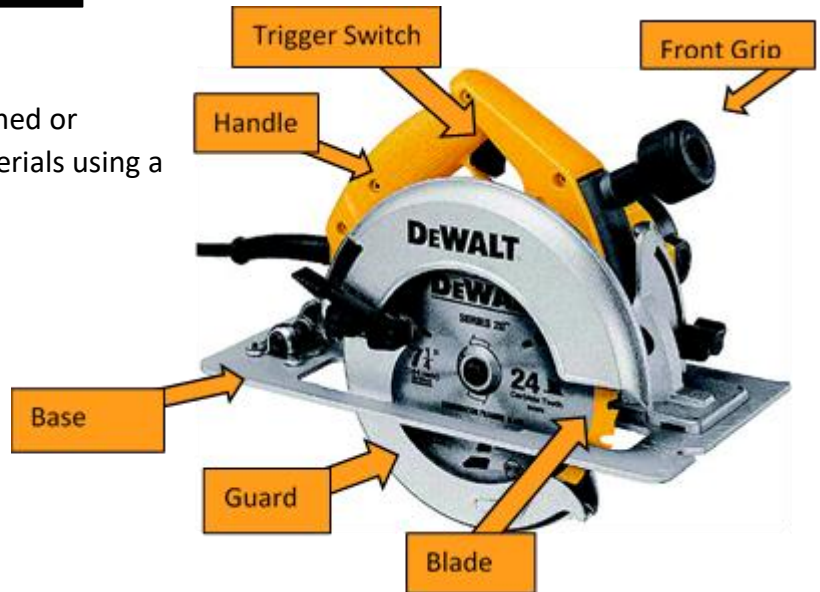

## SAFETY PROCEDURES

- Wear approved eye protection. Ensure long hair is tied back, all jewelry is removed, and that you are wearing closed toed shoes. Approved hearing protection should also be worn while using this piece of equipment.
- Position the stock so that it is stable and stationary and can be cut from a balanced and comfortable position by the operator. Smaller pieces should be secured in a vice or clamped to a bench.
- Pinching the blade is probably the most common mistake made when using a portable circular saw. To prevent it, make sure the two ends fall apart when the wood falls at the end of the cut. If the two ends fall together, they will pinch the blade and cause the saw to kick back towards you.
- Never use a portable circular saw if the blade guard is sticking. It is too easy to forget about the guard and set the saw down while the blade is spinning unprotected. If you do this, the saw will run in a circle on the floor towards you.
- Make sure the line of cut is clear underneath because you can't see the bottom of the blade. It will cut through anything it runs into. Lots of people have been shocked when their saw cut its own cord, or when the sawhorse they were working on split in half.
- Let the saw reach full speed before you begin your cut. If the blade is touching the wood when you pull the trigger, the saw will kick back towards you.
- The rotation of the blade on a portable circular saw is such that if there is a problem, the saw will jump back towards you. Keep a firm grip on the saw at all times. Keep in mind that things behind the saw, like feet or fingers, are in more danger than things in front of the saw—it never jumps forward!
- The blade should be set so that no more than  $\frac{1}{4}$ " (5mm) is exposed on the bottom side of the material. This will reduce the chance of kick back and potentially deep cuts in case of an accident.

## Portable Circular Saw Safety Test

Student Name: \_\_\_\_\_

Date: \_\_\_\_\_

	TRUE/FALSE	
1. Eye and hearing protection is not required for using the portable circular saw.	T	F
2. You should always keep a loose grip on the saw when cutting.	T	F
3. Smaller pieces of wood should always be secured in a vice or clamped to a bench before cutting.	T	F
4. The blade should be set so that no more than ¼" (5mm) is exposed on the bottom side of the material.	T	F
5. It is safe to begin cutting before the saw is at full speed.	T	F
6. You should position the stock so it is stable and stationary.	T	F
7. Always make sure the safety guard is moving freely before cutting.	T	F
8. You should always be aware of the location of the cord and that it can move freely as you cut	T	F
9. Make sure the cut is clear underneath your material.	T	F
10. You don't need to be concerned about your hands and feet when cutting.	T	F
I have discussed shop safety with the instructor and understand that I need to be careful when working around power tools so nobody gets injured.  Signed: _____	SCORE:    /	

## RADIAL ARM SAW

A radial arm saw is a cutting machine consisting of a circular saw mounted on a sliding horizontal arm.

### Important parts:

- Table
- Radial arm
- Blade assembly
- Upper blade guard
- Lower blade guard



## SAFETY PROCEDURES

- Wear approved eye protection. Ensure long hair is tied back, all jewelry is removed, and that you are wearing closed toed shoes. Approved hearing protection should also be used while operating this machine.
- Make sure the blade guard is in place and works properly.
- It is not safe to cut wood that is less than 300mm long on the radial arm saw because your fingers will end up too close to the blade.
- Make sure the wood you are cutting is well supported, and not stacked above the fence. If you are cutting a bunch of pieces at once (gang cutting) make sure they are piled securely, otherwise the blade could find a loose piece and snap it towards the fence. This would take the cut out of your control.
- Check wood for knots and non-wood material such as gravel, nails, etc.
- Keep your hands at least 150mm to either side of the blade at all times. The area in front of the blade is always dangerous because the carriage could come forward at any time, e.g., if the blade hooked a small piece of scrap. Use another piece of wood to push cuts clear of this area- don't use your hand.
- The radial arm saw has a tendency to pull itself into the cut because of the way the blade rotates. Anticipate this and control the rate of feed carefully.
- When you have finished with the saw, lock the carriage behind the fence so that the blade is secured safely out of the way when the next person comes to use it.
- Never cross your arms when using the radial arm saw.
- Do not cut round or irregular stock unless it is secured. The force of the blade can twist the wood around and pull your hand into its path.
- If a stop is being used, hold the wood against the fence between the stop and the blade.
- Some radial arm saws have a small table. Make sure the ends of long boards are supported to prevent the middle from flipping as you finish a cut.

## TABLE SAW

The table saw is a circular saw mounted under a table that allows the blade to protrude through a slot.

### Important parts

- Blade
- Overhead guard
- Table
- Blade tilt adjustment
- Fence
- Blade height adjustment

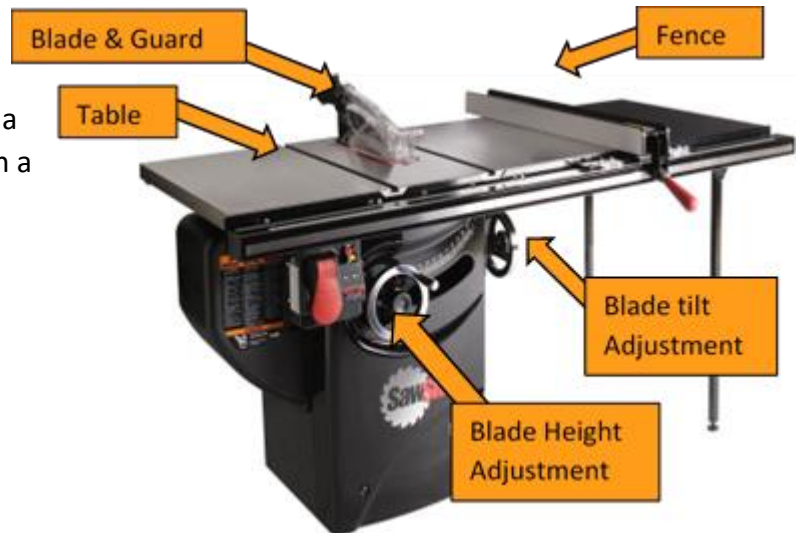

## SAFETY PROCEDURES

- Wear approved eye and hearing protection. Ensure long hair is tied back, all jewelry is removed, and that you are wearing closed toed shoes.
- Prior to use, ensure all guards, anti-kickback fingers and splitters are in place and functional. Never make free hand cuts on the table saw. It is too easy to twist the wood or pinch the blade. Always use either the fence or the mitre gauge.
- Always use the guards, splitter and anti-kickback fingers unless you have authorization to remove them. Under special circumstances, e.g., dadoing or undercutting, and then they are to be reinstalled immediately.
- Set the blade height to clear the wood by about 5mm. If you set it higher, you may create a hazard. Only set it lower for special circumstances such as undercutting or partial cutting.
- Never cut stock that is less than 300 mm long. Small stock is dangerous because: a) it brings your fingers closer to the blade and, b) it can kick back more easily because it is lighter.
- Always use a push stick if your fingers will come within 100mm of the blade.
- Wood can 'kick back' out of the table saw. In fact, this is one of the most common table saw accidents. Stand to the side when rip cutting so that you won't get 'kicked.'
- When cutting on the table saw, always support the wood on its longest side. Use the fence when rip cutting, and use a miter gage or cross cut jig for cross cutting. Never use the fence when crosscutting-you will have an accident!
- Always push the stock between the blade and the fence until it has passed the back of the blade; otherwise, the wood inside the fence could easily be caught by the blade and kicked back.
- If you are taking stock off the back of the saw, reach around the blade, not over it. If possible, have someone help you or let the stock drop to the floor. Never reach around or over a running saw. Shut it off first.



## Table Saw Safety Test

Student Name: \_\_\_\_\_

Date: \_\_\_\_\_

	TRUE/FALSE	
1. The height of the blade should be set to clear the wood by about ¼' (5 mm).	T	F
2. Guards, kick back fingers and splitters are typically not required.	T	F
3. It is acceptable to make free hand cuts on the table saw.	T	F
4. The min. length of wood that can be cut on the table saw is 12" (300mm).	T	F
5. Wood can kick-back out of the table saw.	T	F
6. You should never use the fence when cross cutting on the table saw.	T	F
7. Push sticks should be used if your fingers could come within 6" (150mm)	T	F
8. Eye and hearing protection is not necessary on the table saw.	T	F
9. It is acceptable to reach over the blade while it is running to retrieve material.	T	F
10. Use a miter gage or cross cut jig when performing cross cutting operations.	T	F
I have discussed shop safety with the instructor and understand that I need to be careful when working around power tools so nobody gets injured.  <b>Signed:</b> _____	<b>SCORE:</b> /	

## WOOD LATHE

A wood lathe is a tool that rotates the work piece on its axis to perform various operations such as cutting, sanding, knurling, drilling, deformation, facing, or turning with tools that are applied to the work piece to create an object with symmetry about an axis of rotation.

### Important parts:

- Head stock
- Tail stock
- Tool rest

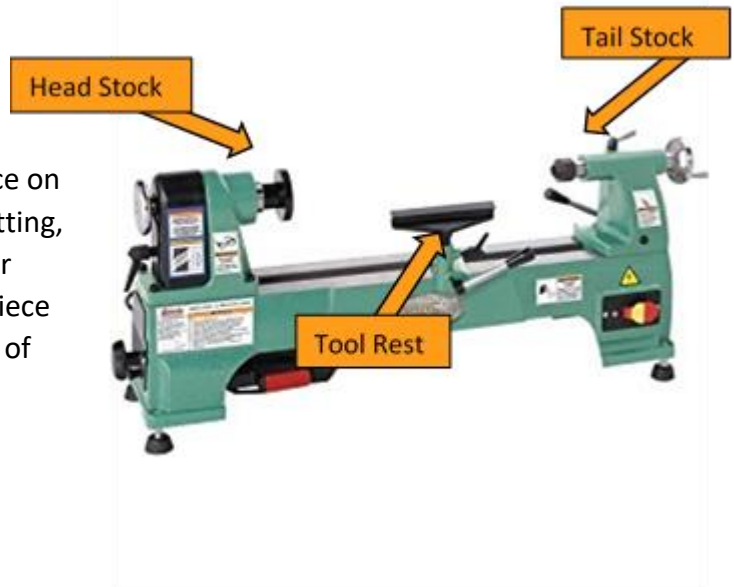

## SAFETY PROCEDURES

- Wear approved eye protection. Ensure long hair is tied back, all jewelry is removed, and that you are wearing closed toed shoes.
- When setting up a turning in the lathe, make sure the wood is solidly mounted and all locks are secure. Many lathe accidents result when wood jumps off the machine.
- Inspect the stock for bad glue joints, loose knots or severe checks. Any of these defects could cause an accident.
- Keep the tool rest close to the work at all times-within 12mm, if possible. As you turn a project and the gap between the wood and the tool rest increases, so does the chance of the chisel catching.
- Make it a habit to rotate the stock by hand before turning on the lathe. This will let you know if anything is going to bump when you turn on the power.
- Begin turning the lathe at a low speed. The wood may be unbalanced (especially large, rough stock) and could vibrate badly at high speed.
- Hold the chisel close to each end, not in the middle. Your front hand should control the cut by riding against the tool rest. Your backhand should steady the chisel by holding the butt against your hip.
- Remove the tool rest from the lathe when sanding or finishing your project so there is no danger of pinching your fingers.

## Wood Lathe Safety Test

Student Name: \_\_\_\_\_

Date: \_\_\_\_\_

	TRUE/FALSE	
1. Safety glasses must be worn at all times	T	F
2. Gloves should be worn when using this machine	T	F
3. Loose clothing and jewelry is acceptable while working on the lathe	T	F
4. The chuck key must never be left in the chuck	T	F
5. Use your hand to slow down the chuck so that you can leave the machine quicker	T	F
6. Use extreme caution if your stock sticks through the headstock end	T	F
7. Do not use your hand to remove material	T	F
8. Long hair must be tied back	T	F
9. The bed and slide area is a good place to store you tools	T	F
10. Ask permission to use the machine before using	T	F
I have discussed shop safety with the instructor and understand that I need to be careful when working around power tools so nobody gets injured.  Signed: _____	SCORE: /	

## SLIDING COMPOUND MITRE SAW

A portable or fixed mounted saw that allows the user to create bevels at any angle. Sliding compound miter saws have all the versatility of compound miter saws and a sliding feature, similar to a radial arm saw, allowing you to move the blade forward and backward, increasing the user's ability to cut larger widths of material.

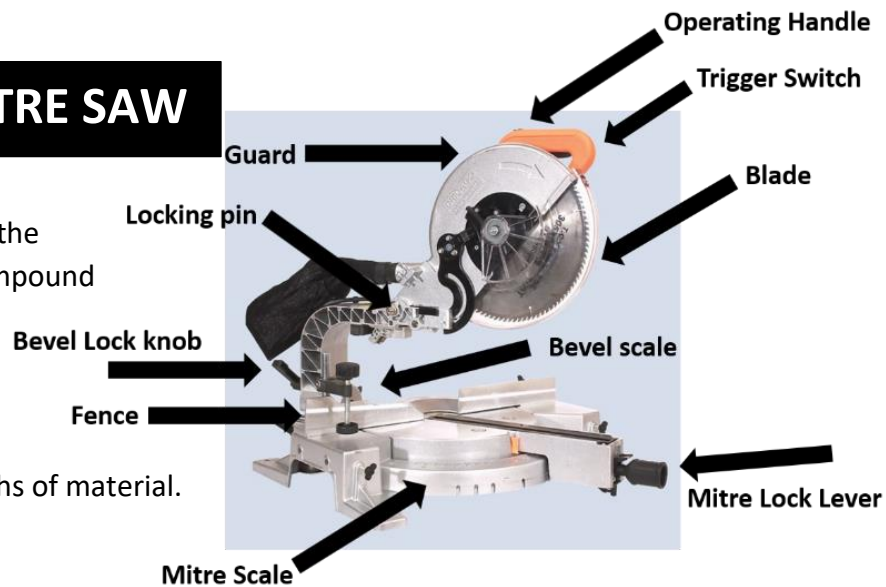

### Important parts:

- Guard
- Locking pin
- Trigger switch & handle
- Bevel lock knob
- Bevel scale
- Mitre scale
- Mitre lock lever
- Fence

## SAFETY PROCEDURES

- Wear approved eye protection. Ensure long hair is tied back, all jewelry is removed.
- Always use your right hand on the trigger switch when cutting wood on the mitre saw.
- Proper positioning of your body and hands when operating the miter saw will make cutting easier, more accurate and safer. Never place hands near cutting area. Your hands must be at least 150mm (6") away from the blade.
- Do not cross your arms when cutting on the mitre saw or reaching for material.
- Always push the saw away (towards the fence) from you when you are slide cutting.
- Cut slowly, especially on wide or thick pieces. Fast cuts leave a poor finish and can jam the blade.
- The mitre saw is for cross-cutting only.
- Use a "stop" when cutting several pieces of the same length.
- Keep the saw and work area clear and free of debris, wood chips, sawdust and tools for safe and accurate work. Dispose of all trimmings in the appropriate containers.
- Always secure the wood against the fence.
- If the wood is warped, the bow goes out and the cup goes up.

## Sliding Compound Mitre Saw Safety Test

Student Name: \_\_\_\_\_

Date: \_\_\_\_\_

	TRUE/FALSE	
1. Always wear approved eye and hearing protection when operating the Sliding Compound Mitre Saw.	T	F
2. When using the mitre saw, fingers should be at least 150mm (6") away from the blade.	T	F
3. When cutting multiple pieces of wood, a 'stop' creates consistency in your cuts.	T	F
4. Always pull the saw towards you when cross-cutting wide pieces.	T	F
5. A mitre saw is used for cross-cutting only.	T	F
6. Material should always be held securely before cutting.	T	F
7. Use either your right or your left hand to cut and the other hand to hold the wood in position on the table.	T	F
8. Always make sure the guard is moving freely.	T	F
9. You should always keep the working area clean and free of debris.	T	F
10. Fast cuts leave a nice finish and prevent the blade from jamming.	T	F
I have discussed shop safety with the instructor and understand that I need to be careful when working around power tools so nobody gets injured.  Signed: _____	SCORE:    /	

## DISC / BELT SANDER

A combination power sander that is stationary in the shop. It has replaceable abrasive sanding surfaces. Used for removing large amount of material.

### Important Parts:

- Work table
- Disc surface
- Belt surface
- Work table angle adjustment

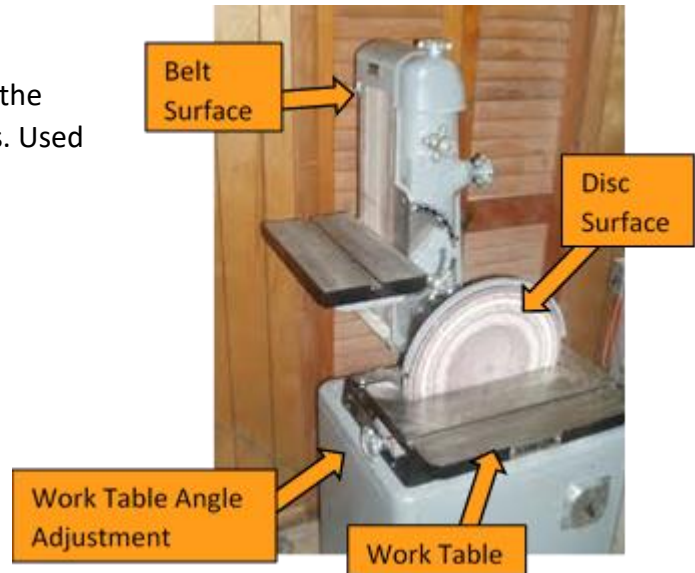

## SAFETY PROCEDURES

- Wear approved eye protection
- When using the belt/disc sander, always keep your material flat on the work table.
- If you wish to sand on an angle, always use a miter gauge or tilt the table.
- Hands / Fingers should be at least 2" away from the moving abrasive surfaces.
- Sand side to side so that you wear the belt evenly. If you stay in one spot too long you will damage the belt and it may break.
- When sanding on the disc, always sand on the side of the disc turning down towards the work table. Do not sand on the side with upward motion as the disc will lift your material and could throw your material into the air.
- Never wear gloves on the belt/disc sander. If you get your fingers too close the gloves will pull your hands in.

## Disc/Belt Sander Safety Test

Student Name: \_\_\_\_\_

Date: \_\_\_\_\_

	TRUE/FALSE	
1. Sanding can be safely done on either the left or right side of the rotating disc.	T	F
2. You can use the disc/belt or spindle sander even if the sanding disc/belt is damaged.	T	F
3. Your wood must be held flat against the table. You cannot lift it off the table otherwise you could get injured.	T	F
4. You may make adjustments to the table while the machine is running to get the correct angle you want.	T	F
5. Two people can work on the machine at the same time.	T	F
6. Before I start the machine, I should check the angle of the table to make sure it is correct.	T	F
7. I can leave the machine as soon as I turn it off.	T	F
8. Hands and fingers should be no closer than 2" (5cm) to the moving abrasive.	T	F
9. Always check with the teacher if you plan any special operations with the disc/belt sander.	T	F
10. If you are changing the abrasive disc or belt, make sure the machine is off and the power is disconnected.	T	F
I have discussed shop safety with the instructor and understand that I need to be careful when working around power tools so nobody gets injured.  Signed: _____	SCORE:    /	

## CNC WOOD ROUTER

A computer numeric controlled cutting machine that uses computer coded programming to operate the wood router. Often used in manufacturing to ensure precise cutting.

### Important Parts:

- Work table
- Router
- Collet
- Gantry

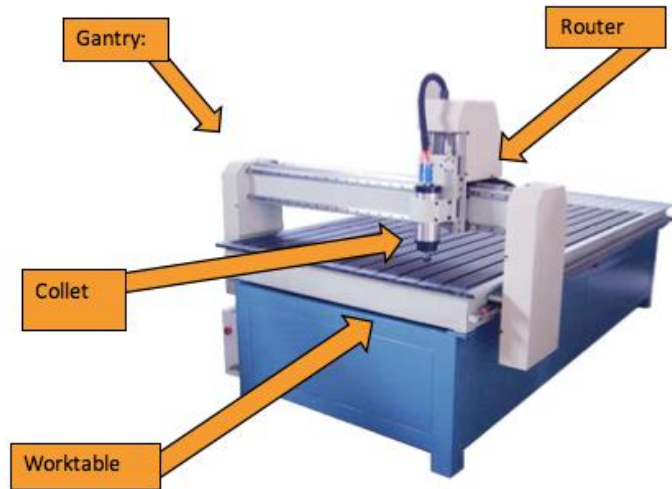

## SAFETY PROCEDURES

- Wear safety glasses while using the CNC Wood Router.
- Always wear ear protection when working with the plasma cutter.
- Ensure that you have adequate ventilation and that it is turned on before use.
- Verify that your toolpath is going the correct direction, and that the origin point is in the correct location to avoid damaging the machine. Ask your teacher to inspect the program before you export it.
- Verify that your material has no metal (screws, nails, staples etc.).
- Using a small brush, sweep any sawdust and woodchips off of the machine table before you mount your material on the machining table.
- Mount your material at the origin point of the router bed. Ensure that it is fastened securely and that your clamps/screws are outside of the toolpath. Ask your teacher to inspect the material before you proceed.
- Keep your hand over the emergency stop to stop the machine in the event of a machining error, a Z-axis crash, material movement or accident.
- Before starting the cut, ensure that the machining area is clear of any obstructions.
- While cutting, ensure that you are standing a full step away from the machine and keep all extremities away from the pinch points of the gantry while the machine is operating.
- Before changing the router bit, lock out the controller/unplug the router to ensure that it does not turn on, do not re-engage the router until the router bit change is complete and all tools are removed from the router bed.
- When the machine has finished cutting and the router bit has come to a stop, move the gantry away from your work.



## THICKNESS SANDER

A stationary piece of equipment used in fine sanding of large surface areas. Especially effective on figured woods. Not designed to remove large chunks of material.

### Important Parts:

- Control panel
- Conveyor belt
- Sanding drum(s)
- Height adjustment lever



## SAFETY PROCEDURES

- Wear approved eye protection.
- Do not wear gloves while operating the sander.
- The sanding drum/belt can cause serious burns to skin if accidentally caught in between the sanding drum/belt and the conveyor.
- Do not sand pieces too small to be safely supported through the machine. The minimum material length is 12 inches.
- A dust collector should be used for dust control while operating sander.
- The access panel covering the drum/belt must remain closed while machine is in use.
- Check for wear or damage on conveyor belt before turning machine on. Ripped belts or burn marks need to be reported to the instructor.
- Stand clear of machine infeed while using to avoid material kickback.
- Feeding more than one piece into the sander simultaneously may result in kickback.

## EDGE SANDER

A stationary piece of equipment designed for sanding the edges of wood materials.

### Important parts:

- Work table
- Belt surface
- Table height adjustment
- Belt tension lever

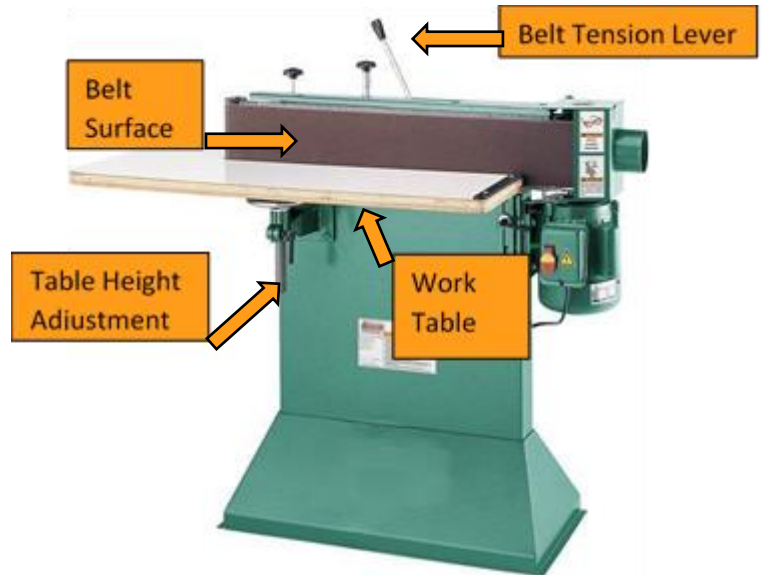

## SAFETY PROCEDURES

- Wear approved eye protection.
- Make sure belt is tracking correctly and is not torn or loose.
- When changing a belt ensure the belt is installed as the direction indicates.
- Always keep hands away from abrasive surface.
- Make all adjustments except final belt tracking with power off.
- Ensure dust collection system is switched on before use.
- The table should be positioned a maximum of a 1/8" from the belt.
- Shut off power and do not leave until the machine has come to a complete stop.

## SPINDLE SANDER

A stationary oscillating sander used for sanding inside curves. The machine has a variety of different sized inserts to custom fit the work piece.

### Important parts:

- Spindle table
- Angle lock
- Spindle insert
- Table

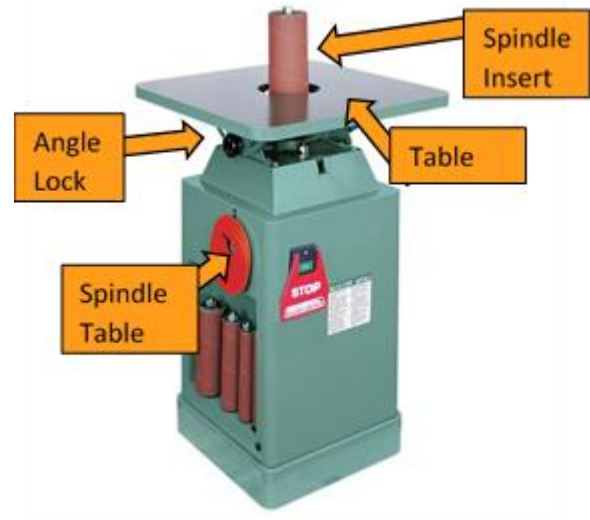

## SAFETY PROCEDURES

- Ensure that there is adequate ventilation and that it is turned on before use.
- Always wear eye protection.
- Do not wear gloves or loose clothing.
- Check to see that the spindle insert fits closely to the spindle with a minimum of clearance: too large an opening may lead to the work piece becoming caught between the spindle and the worktable.
- If there is a tear or loose piece on the sanding spindle, notify the teacher immediately.
- When you first turn the machine on, check to see if the spindle wobbles. This indicates either a loose spindle that needs to be tightened or a bent spindle that needs replacement. Do not use until repaired by the teacher.
- Always place work piece on the table first, then push the work against the rotating spindle.
- Feed the stock against the rotation of the spindle, periodically removing it to prevent damage to the sandpaper and burning of the work piece.
- If you are sanding on an angle, ensure that the table is locked securely using the angle lock, and only sand your material on the downhill side of the spindle.
- If you are sanding an interior profile (i.e. a hole), ensure that you use a spindle that is small enough in diameter so that there is at least 1" of clearance all of the way around the spindle. Lower the work on to the table with the machine turned off, hold it securely away from the spindle and then turn the machine on. When finished sanding, turn the machine off, wait for the spindle to stop turning, then remove the work piece.

## Spindle Sander Safety Test

Student Name: \_\_\_\_\_

Date: \_\_\_\_\_

	TRUE/FALSE	
1. Eye protection is not required when using the spindle sander.	<b>T</b>	<b>F</b>
2. Always wear gloves when using the spindle sander.	<b>T</b>	<b>F</b>
3. Roll up sleeves and secure loose clothing before sanding.	<b>T</b>	<b>F</b>
4. There should be 1" (2.5cm) clearance around the spindle and an inside profile of your workpiece.	<b>T</b>	<b>F</b>
5. Feed the stock against the rotation of the spindle, periodically removing it to prevent damage to the sandpaper and burning of the work piece.	<b>T</b>	<b>F</b>
6. If you are sanding on an angle, ensure that the table is locked securely using the angle lock, and only sand your material on the downhill side of the spindle.	<b>T</b>	<b>F</b>
7. When finished sanding, turn the machine off, wait for the spindle to stop turning, then remove the work piece.	<b>T</b>	<b>F</b>
8. It is acceptable to sand even if the abrasive is torn.	<b>T</b>	<b>F</b>
I have discussed shop safety with the instructor and understand that I need to be careful when working around power tools so nobody gets injured.  <b>Signed:</b> _____	<b>SCORE:</b> /	

## WOOD ROUTER

A wood router is a tool used to rout out (hollow out) an area in the face of a relatively hard work piece, typically of wood or plastic. They are also used to create profiles on the edges of wood.

### Important parts:

- Power switch
- Depth stop
- Collet
- Variable speed adjustment
- Base plate
- Handles x 2



## SAFETY PROCEDURES

- Wear approved eye protection. Ensure long hair is tied back, all jewelry is removed, and that you are wearing closed toed shoes. Approved hearing protection is also recommended when operating this machine.
- Unplug the router before changing the bits-you don't want to bump the switch when your hand is on the cutter.
- Install bits with at least 15mm of the shaft in the collet chuck. Any less and the bit could vibrate loose during use.
- After you have changed the bit, make sure the switch is off before you plug in the router, otherwise you might get an unwanted surprise.
- Unless the object you are going to route is really big and heavy, and won't move around, you need to secure the stock with a vice or clamps. Never hold the stock with one hand while routing with the other.
- When you are ready to go, make sure the bit is clear of the stock before you turn the router on. Once the router is up to speed, cut with even pressure at a steady pace. Don't force the cut or overload the router.
- Always cut against the rotation of the bit. This gives you better control as you push the router into the cut. If you go the other way, the router will pull itself along.
- When you have finished your cut, let the bit completely stop before you put the router down.

## Router Safety Test

Student Name: \_\_\_\_\_

Date: \_\_\_\_\_

	TRUE/FALSE	
1. Eye and hearing protection is not necessary when using the hand router.	<b>T</b>	<b>F</b>
2. Unplug the router if you are going to make any adjustments.	<b>T</b>	<b>F</b>
3. A dull or damaged bit is still safe to use.	<b>T</b>	<b>F</b>
4. Make several passes if removing a large amount of wood.	<b>T</b>	<b>F</b>
5. It is okay to router materials with paint, cracks, knots, etc.	<b>T</b>	<b>F</b>
6. The direction of feed is always with the rotation of the bit.	<b>T</b>	<b>F</b>
7. Plan the cut so that you are balanced.	<b>T</b>	<b>F</b>
8. When using the router table, keep your hands far away from the rotating bit.	<b>T</b>	<b>F</b>
9. You can push the wood through as fast as you can so it will not burn.	<b>T</b>	<b>F</b>
10. Leave the router bit in contact with the wood when turning it off so you don't accidentally catch your wood.	<b>T</b>	<b>F</b>
I have discussed shop safety with the instructor and understand that I need to be careful when working around power tools so nobody gets injured.  <b>Signed:</b> _____	<b>SCORE:</b> /	

## DRILL PRESS (WOOD)

The drill press is used for drilling large holes, for drilling holes perfectly perpendicular or parallel to the stock, or for drilling multiple holes to the same depth.

### Important Parts:

- Depth stop
- Chuck
- Feed crank
- Table

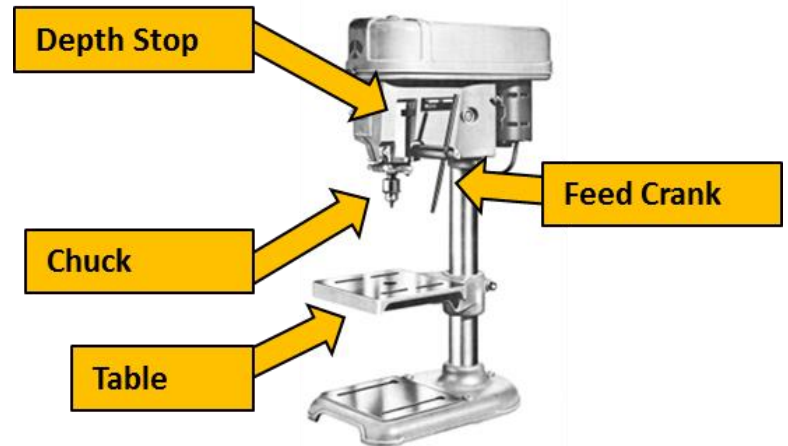

## SAFETY PROCEDURES

- Be sure to tie back long hair before using the drill press, you don't want your hair getting caught in the spinning chuck.
- Tuck in or remove all loose clothing (hoodie strings, jewellery) that could get caught in the drill press.
- The material you intend to drill must be secured in a drill vice or clamped down to the drill press table. This will prevent it from spinning around and hurting you if the drill bit were to catch.
- The chuck on the drill press spins in a clockwise rotation. If drilling into a long work piece, rest one end of the wood against the left hand side of the drill press column to avoid getting hit by the stock if it somehow catches the bit.
- Set an appropriate drill speed for the drill bit (large bits should spin slower, smaller bits should spin faster)
- Make sure the chuck key is out of the chuck every time you go to start the drill.
- Set up your operation to avoid drilling into the vice or table. Put some scrap wood under your work or position the vice so that the bit won't drill it as it passes through the work piece.
- When drilling, advance the drill bit with an even and moderate pressure and reduce pressure as the bit breaks through the bottom of your work piece (this prevents breakout and the chance of the bit catching at the bottom of your hole).

## Drill Press Safety Test

Student Name: \_\_\_\_\_

Date: \_\_\_\_\_

	TRUE/FALSE	
1. Always wear safety glasses.	T	F
2. Remove all jewelry, loose clothing and tie back long hair.	T	F
3. You can hold material with one hand while drilling wood.	T	F
4. Check tool path before starting your procedure.	T	F
5. Never wear gloves while using the drill press.	T	F
6. Leave the chuck key in drill chuck when finished on the machine so the next person can find it.	T	F
7. A high speed is best when using a large diameter drill bit.	T	F
8. Always ask permission before using a machine.	T	F
<p>I have discussed shop safety with the instructor and understand that I need to be careful when working around power tools so nobody gets injured.</p> <p><b>Signed:</b> _____</p>	<p><b>SCORE:</b>    /</p>	



## SCROLL SAW

The scroll saw is a cutting tool with a very thin blade. It is used for cutting sharp curves and intricate designs into thinner stock. The blade travels up and down very quickly in order to cut the wood.

### Important Parts:

- Speed adjustment
- Tension adjustment
- Table
- Pressure foot

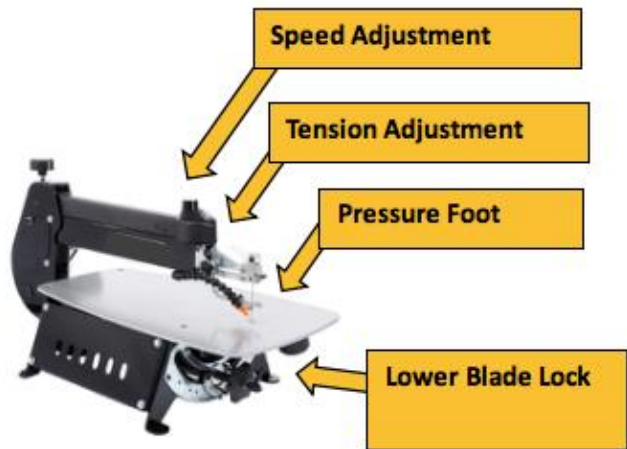

## SAFETY PROCEDURES

- Always wear safety glasses.
- Before cutting on the scroll saw, be sure that the blade tension is properly adjusted to keep the blade from bending or breaking.
- A variable speed scroll saw should be started at the slowest speed setting, and then the speed should be adjusted to a proper speed for the task at hand. The thicker the wood, the faster the speed of the blade.
- If the scroll saw is equipped with a 'pressure foot' or 'hold down foot', be sure to set it down against the stock before turning on the power. This ensures that the stock stays flat against the table and doesn't bounce up and down or 'chatter'.
- When cutting, do not have your hands directly in line with the saw blade. Always keep your hands at least 2" away from the blade at all times.
- Never clear scraps of material near the moving blade with your fingers.
- If small pieces of scrap get caught in the throat against the saw blade, be sure to stop the machine before trying to remove them.
- When installing a new blade, make sure that the power cord is unplugged, and make sure the teeth of the blade are pointing down so that the cutting action is towards the table of the scroll saw.
- The scroll saw works best on stock that is  $\frac{3}{4}$ " (the width of your thumb) or thinner. It cannot be used on stock thicker than  $1\frac{1}{2}$ ".

## Scroll Saw Safety Test

Student Name: \_\_\_\_\_

Date: \_\_\_\_\_

	TRUE/FALSE	
1. When making adjustments or changing the Scroll Saw blade, switch the machine off and disconnect the power if possible.	T	F
2. Make sure your hands are not in front of the blade when cutting.	T	F
3. Do not talk to others while you are using the Scroll Saw.	T	F
4. The hold-down is only necessary with large pieces of stock.	T	F
5. Always clear the table with your hands because you could damage the fragile blade with a brush.	T	F
6. Uneven stock can be easily cut on the Scroll Saw.	T	F
7. The hold-down is used to keep the stock on the table; you do not need to hold it down yourself.	T	F
8. Before backing out of long cuts, turn the power off so you don't break the blade.	T	F
9. Occasionally the blade will break. Shut the machine off and put a new one on yourself.	T	F
10. The thicker the wood being cut, the faster the speed of the blade.	T	F
11. Push the wood to be cut through the blade as fast as possible.	T	F
I have discussed shop safety with the instructor and understand that I need to be careful when working around power tools so nobody gets injured. <b>Signed:</b> _____	<b>SCORE:</b> /	

# **METAL SHOP**

## Metal Shop Safety

Topic	Notes	Student Information
<b>Arc welder</b>	<p>Ensure equipment is correctly installed.</p> <p>All protective gear must be in good condition, including helmets and gloves which must be worn whenever operating an arc welder. All exposed skin must also be protected.</p> <p>Ensure effective local ventilation—respirators may also be required.</p> <p>Explain that hot work must be marked “hot” or effectively guarded to prevent contact.</p> <p>Explain location and use of fire extinguisher.</p>	<ul style="list-style-type: none"> <li>• Wear appropriate protective clothing to protect against electric shock, metal splatter and UV rays</li> <li>• Do not weld in wet conditions</li> <li>• Ensure that cables will not interfere with your work</li> <li>• Wear a welding helmet with a #10 lens or darker</li> <li>• Wear eye protection when chipping or grinding</li> <li>• Ensure effective local ventilation</li> <li>• Suspect everything in a welding area of being hot</li> <li>• Never weld where flammable fumes or liquids may be present, especially tanks or containers</li> <li>• Use screens to protect others from flash</li> </ul>
<b>Bench grinder</b>	<p>Explain rest <math>\leq 1.5\text{mm}</math> (1/8”) clearance from the grinding wheel.</p> <p>No grinding on side of wheel.</p> <p>Explain types of wheels for types of metals. Explain wheel dressing procedure.</p>	<ul style="list-style-type: none"> <li>• Full face shield is required.</li> </ul>

## Metal Shop Safety (cont.)

Topic	Notes	Student Information
<b>Buffer and Wire Wheel</b>	<p>The buffer can be very dangerous so the safety rules are very important to understand and follow.</p> <p>Eye protection is required; 2 pieces. Safety glasses and face shield</p>	<ul style="list-style-type: none"> <li>• Hold the work just below the center of the wheel and always buff “off” the edge</li> <li>• A build-up of heat while buffing can be dangerous</li> <li>• Eye protection is required, safety glasses and face shield</li> </ul>
<b>Drill Press</b>	<p>Long hair must be tied back, and strings or jewelry that could get caught must be removed.</p> <p>Explain set up, drill speed and tightening precautions.</p> <p>Eye protection is required.</p>	<ul style="list-style-type: none"> <li>• Secure the stock in a drill vice or clamps</li> <li>• Center punch hard materials before drilling</li> <li>• Make sure the chuck key is clear before starting the drill</li> <li>• Make sure the bit is clear of stock before moving the stock</li> <li>• Set up your operation to avoid drilling the vice or the table</li> <li>• Eye protection is required</li> </ul>
<b>Foundry Operations</b>	<p>Moisture is a constant hazard when pouring molten metal. If there is moisture in the ingots, casting stock, concrete or mold, it can instantly vaporize and explode from the heat of the molten metal.</p>	<ul style="list-style-type: none"> <li>• Do not light or adjust the furnace unless you have been authorized to do so</li> <li>• Preheat metal before adding it to a pot of molten metal</li> <li>• Wear a mesh face guard and burn-proof gloves and leggings when pouring a cast</li> <li>• Stand to the side as you pour a casting, molten metal falling on cold concrete can cause it to fracture and pop</li> <li>• Use caution to avoid burning yourself when opening up a recent casting</li> <li>• Freshly poured castings must be marked “HOT”</li> </ul>

## Metal Shop Safety (cont.)

Topic	Notes	Student Information
<b>Metal Cut Off Saws</b>	<p>There are a variety of cut off saws in use—power hack saws, horizontal band saws, chop saws—but the safety procedures for all are similar.</p> <p>If your cut off saw has an unusual feature or characteristic, remember to add it to this lesson.</p>	<ul style="list-style-type: none"> <li>• Make sure the stock is securely clamped in place</li> <li>• Keep your hands clear of the path of the blade at all times</li> <li>• Let the cut proceed at a comfortable pace—do not force it</li> <li>• Monitor the cut as it progresses to ensure that it proceeds smoothly and the saw shuts off on completion</li> <li>• Be careful when handling freshly cut pieces as they may be very hot and/or have sharp burrs on them</li> <li>• Clean the machine with a brush, not your hand</li> <li>• Wear eye protection and appropriate gloves when handling stock</li> </ul>
<b>Metal Lathe</b>	<p>Common accidents on the metal lathe involve clothing caught in moving parts and long pieces of stock extending through the headstock and whipping around.</p> <p>Explain the hazards involved in using cutting fluids.</p>	<ul style="list-style-type: none"> <li>• Make sure the stock is secure and the locks are tight before turning on the lathe</li> <li>• Never leave the chuck key in the chuck</li> <li>• Any material that extends more than twice its diameter from the chuck should be supported by the tailstock or a steady rest</li> <li>• Use extreme caution whenever material extends through the headstock</li> <li>• Tuck in shirt-tails or they may get caught in the lead screw</li> <li>• Use ear and eye protection</li> <li>• Use gloves when handling stock but not while handling the lathe</li> </ul>

## Metal Shop Safety (cont.)

Topic	Notes	Student Information
<b>Oxy-acetylene Torch</b>	<p>Explain that hot work must be marked “hot” or effectively guarded to prevent contact.</p> <p>Explain location and use of fire extinguisher. Ensure flashback arrestors and uniflow valves are included.</p> <p>Ensure effective local ventilation—respirators may be required.</p> <p>Ensure acetylene cylinders are kept upright.</p>	<ul style="list-style-type: none"> <li>• Never use grease or oil to lubricate fittings</li> <li>• Never weld where flammables may be present, especially tanks or containers</li> <li>• Check for leaks by listening or brushing with soapy water</li> <li>• Open cylinders slowly, ½ turn at a time</li> <li>• Always wear leather gloves and welding goggles</li> <li>• Ensure effective local ventilation, especially with galvanized metal, brass or bronze</li> <li>• Be aware of the location of the hoses at all times</li> <li>• Light with a striker, acetylene first</li> <li>• Suspect everything in a welding area of being hot</li> <li>• Always be conscious of where you are pointing the torch; do not put it down unsecured or flaming</li> <li>• When finished, turn off torch valves, turn off the cylinder valve, then go back to the torch and bleed the lines</li> </ul>
<b>Right Angle Grinder</b>	<p>Ensure no flammables are in the area. Guard must be installed.</p> <p>Explain rpm of disk must match rpm of grinder.</p>	<ul style="list-style-type: none"> <li>• Inspect grinder to ensure no cracks in the abrasive disc</li> <li>• Never remove the guard</li> <li>• Secure the stock before grinding it</li> <li>• Grind with light to moderate pressure only</li> <li>• Be conscious of where the sparks expelled by the grinder are going and avoid endangering others</li> <li>• Beware of burns, as the material being ground will get hot</li> <li>• Wear ear and eye protection and flame resistant clothing</li> </ul>

## Metal Shop Safety Test

Student Name: \_\_\_\_\_

Date: \_\_\_\_\_

	TRUE/FALSE	
1. When chipping and grinding you do not need eye protection,	T	F
2. When you are welding it is other people's responsibility to worry about eye protection from flash.	T	F
3. Do not weld tanks or containers that may have or had flammable products in them.	T	F
4. Wire wheels require that you wear 2 pieces of eye protection, safety glasses and face shield.	T	F
5. Secure loose clothing and long hair when working on or around machinery.	T	F
6. Sandals are an acceptable form of footwear in the metal shop.	T	F
7. Chuck keys should be left in the chuck for the next person to find.	T	F
8. Hot metal should be marked so others do not touch.	T	F
9. Always clamp metal down when using a drill press or metal cut off saw.	T	F
10. Eye protection is mandatory when using any machine or power tool.	T	F
I have discussed shop safety with the instructor and understand that I need to be careful when working around power tools so nobody gets injured.  Signed: _____	SCORE: /	



## ARC WELDING

Arc welding is most commonly used to join two pieces of metal. Arc welding is a process where the welder creates an electric arc that melts the base metals and filler metal (consumable) together so that they all fuse into one solid piece of metal.

### Important parts:

- Ground clamp
- AC/DC constant power
- Electrode holder

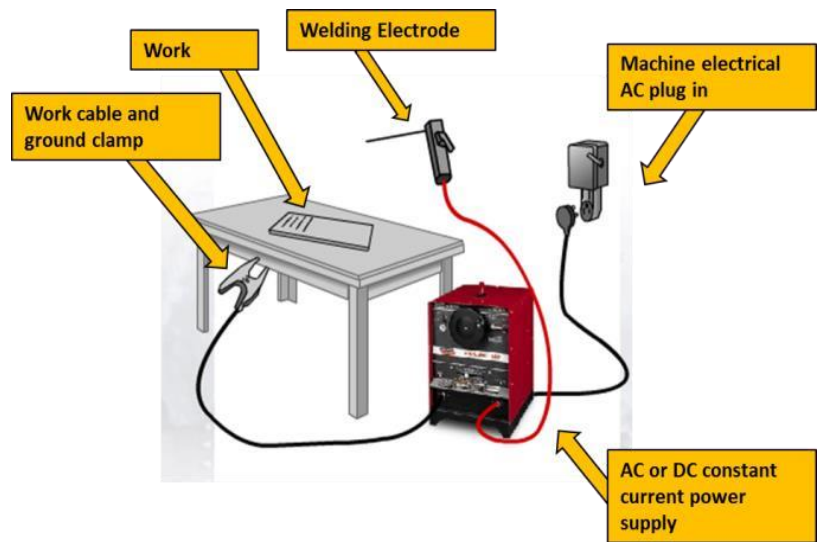

## SAFETY PROCEDURES

- Arc welding can burn or shock you. Wear protective clothing to protect exposed skin from welding splatter and UV rays, and wear leather gloves (without holes) to protect against burns and shock.
- Use screens to protect others from flash.
- Do not weld in wet conditions or while wearing wet clothing. Water is a good conductor and could cancel out the protective qualities of your clothing and gloves.
- Always wear an approved arc welding helmet with a # 10 lens or darker. The light from arc welding is bright enough to damage your eyes permanently. Gas welding goggles or sunglasses are not good enough. Do not watch the arc when someone else is welding and make sure they don't watch you work unless they also have a helmet on.
- Wear clear eye protection when chipping, brushing or grinding your welds.
- Ensure that cables will not interfere with your work.
- Arc welding makes a lot of smoke. Make sure you have effective local ventilation to clear away the fumes.
- Make a habit of feeling, not touching, for heat before you grab anything. Vices, tools or steel near your weld can give a serious burn even though they may not look hot.
- Vapors or fumes from solvents, fuels or other flammable liquids can be explosive. Never weld a container that has held flammables unless it has been steam cleaned or is filled with water.
- Mark hot work "Hot" or guard it so it can't be contacted.

## BENCH GRINDER

A fixed mounted grinding machine used to drive abrasive wheels. May be used for sharpening tools or roughly shaping tools.

### Important parts:

- Eye shield
- Coarse wheel
- Fine wheel
- Tool rest



## SAFETY PROCEDURES

- Wear approved eye protection. Full face shield, leather apron and hearing protection are recommended.
- Inspect the grinder prior to use to ensure there are no cracks in the abrasive disc.
- Check there are no flammables in the area of the grinder
- Keep the tool rest within 1.5mm of the stone at all times. If there is too much room between the stone and the rest, your work could jam causing the stone to shatter.
- Make sure the shields are in place and adjusted properly.
- If the stone has a flaw, it is most likely to fly apart as it speeds up, just after you start it. Always stand to the side when starting the grinder, just in case
- Only grind on the face of the stone, never on the side-it could explode in your face.
- Use moderate pressure when grinding. If you push too hard, you will stress the machine and the stone, and generate unnecessary heat in the material you are grinding
- Avoid grinding small pieces. Instead, hold them firmly in pliers. Small pieces could easily be pulled out of your grasp and cause problems.
- Do not grind sheet metal or soft metals like brass or aluminum on the grinder. Sheet metal vibrates and can easily get caught and non-ferrous metals such as aluminum can quickly plug up the stones.
- Grinding generates a lot of heat in the metal being ground. Cool your material regularly and take care not to burn yourself when it is hot.

## SHEET METAL BOX & PAN BRAKE

A machine that is used to create bends, hems, and boxes in sheet metal. The box and pan brake has movable fingers that allow you to perform more functions than a bar folder. It allows you to get in between bends of sheet metal to create complex shapes.

### Important parts:

- Clamping bar handle
- Counterweights
- Clamping Fingers / Upper clamping bar
- Bending leaf

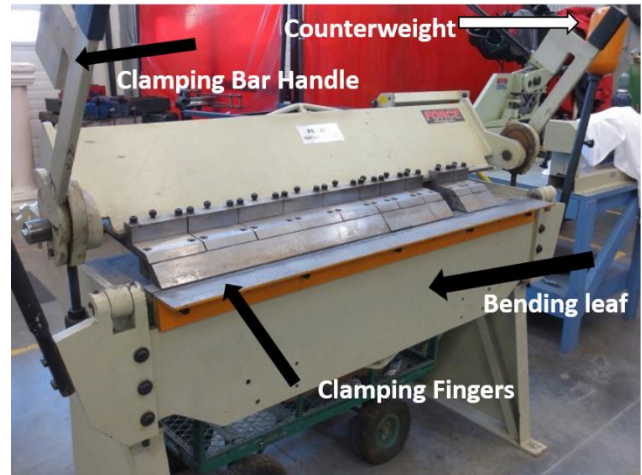

## SAFETY PROCEDURES

- Wear approved eye protection. Ensure long hair is tied back, all jewelry is removed, and that you are wearing long pants and closed toed shoes.
- Keep hands away from the Clamping fingers/ Upper clamping bar.
- Make sure your material is secured in the brake before beginning your fold.
- Ensure the area around the counterweights is free of obstacles.
- Be sure to hold the bending leaf until you have completed your fold. Do not let it drop uncontrolled.

## HORIZONTAL BANDSAW

A saw in which the blade is a continuous band of metal that moves through the material. The material is held stationary in a clamping vice and the blade moves through it using hydraulics.

### Important parts:

- Blade
- Blade tensioning hand wheel
- Base
- Clamping vice
- Blade guard
- Control panel
- Chip/shaving tray

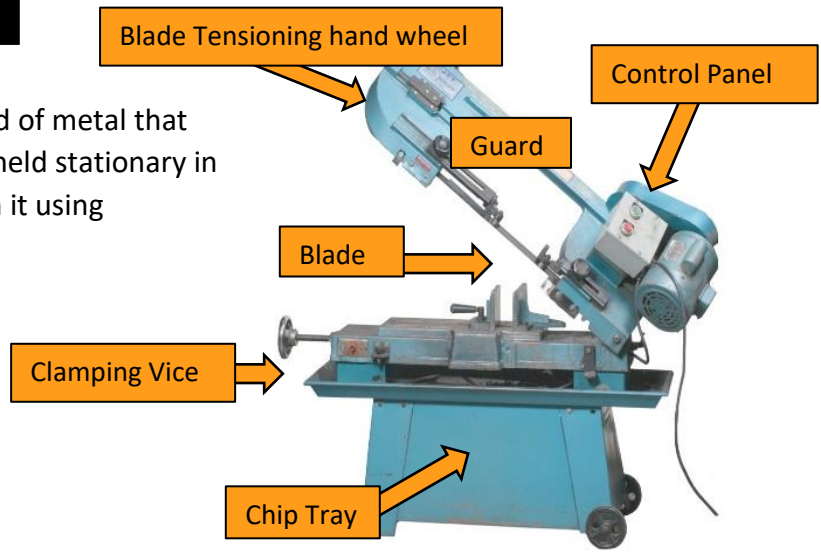

## SAFETY PROCEDURES

- Wear approved eye protection. Ensure long hair is tied back, all jewelry is removed, and you are wearing long pants and closed toed shoes.
- Inspect equipment for loose or broken parts. Report any issues to your instructor.
- Ensure the control panel is in the off position.
- Keep belt guard, blade guards, and wheel covers in place and in working order. Make sure the guards are as close to the vice jaws as possible.
- Make sure your material is clamped safely in the vice. Never hand hold the material.
- Always provide support for long or extra-large pieces of material.
- Standing to the side of the equipment turn the control panel on. Ensure the coolant is on and flowing onto the blade. No coolant should spray onto the floor, adjust accordingly.
- Adjust the speed of the hydraulic arm for the specific material you are cutting. Thick material should have a slower cutting speed.
- Allow the hydraulic arm to begin cutting. Keep hands and face away from the blade and moving parts.
- Wait until the saw has completely passed through the material. Do not handle the unclamped portion of the material, let it fall into chip tray.
- Turn off all components of the control panel.
- Lift the hydraulic arm up and release the material from the clamping vice.

## VERTICAL BANDSAW

A saw in which the blade is a continuous band of metal that moves vertically through the material. Only one side of the blade band has teeth which keeps the blade location stationary while the material is moved through the blade.

### Important parts:

- Blade
- Guard
- Mitre slot
- Upper roller bearing
- Lower roller bearing
- Table tilt knob

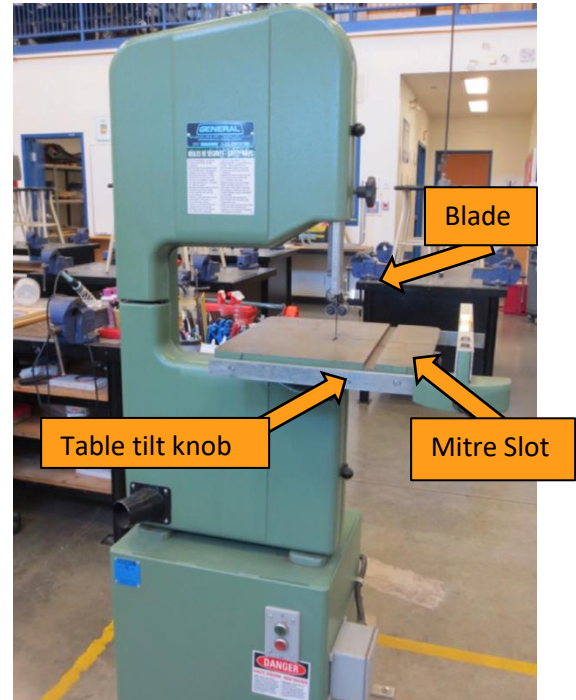

## SAFETY PROCEDURES

- Wear approved eye protection and hearing protection. Ensure long hair is tied back, all jewelry is removed, and you're wearing closed toed shoes.
- While cutting and keep your fingers at least 5cm away from the blade at all times. You cannot cut your fingers if you don't touch the blade
- Set the upper guide and blade guard so they are just above the stock. This guards the blade and helps to keep the cut straight. The upper guide should be within 3mm of the metal.
- Always feed the stock with light pressure and avoid excessive twisting of the blade. If you push too hard or twist too much, you will hear the saw slow down. This is your cue to lighten up. Too much pressure or twisting can break the blade. Use even less pressure as you near the end of a cut because the blade will come out the last millimeter or so.
- If you have several cuts to make, plan your work so you can proceed in a sensible order. Never back out of long, curved cuts.
- Use relief cuts on sharp corners. Thinner blades can cut sharper corners without relief cuts.
- Round or irregular shaped metal presents special dangers because the force of the blade can twist it out of your control. Never cut round or odd shaped pieces unless you use a jig to stabilize them.
- If the blade breaks, turn off the machine and tell your teacher.
- Do not stand to the right of the band saw while someone else is using it. If the blade breaks, it might flip out in that direction.

## Vertical and Horizontal Bandsaw Safety Test

Student Name: \_\_\_\_\_

Date: \_\_\_\_\_

	TRUE/FALSE	
1. Always wear safety glasses on a bandsaw	T	F
2. If the blade breaks turn off machine and tell the teacher	T	F
3. You can back out of long curved cuts with the machine still on	T	F
4. Make adjustments to the machine while it is cutting	T	F
5. Ensure your fingers are at least 2" away from the blade	T	F
6. The vertical bandsaw guide should be less than ¼" above stock	T	F
7. Horizontal bandsaw hydraulic arm speed should always be the same	T	F
8. Guards can be removed if not in working order	T	F
9. Always clamp materials when using horizontal bandsaw	T	F
10. Ask teacher permission before using	T	F
I have discussed shop safety with the instructor and understand that I need to be careful when working around power tools so nobody gets injured.  Signed: _____	SCORE:    /	

## BUFFER /WIRE WHEEL

A fixed mount machine that is used in the polishing of ferrous and non-ferrous materials.

### Important Parts:

- Buffer arbour
- Wheel flanges
- Arbour nut

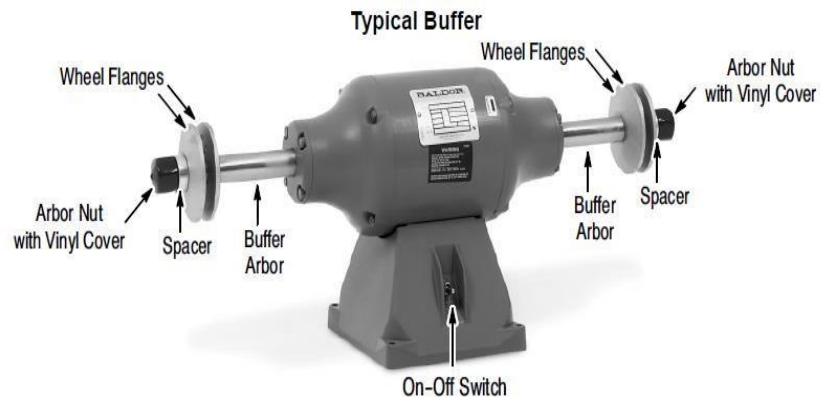

## SAFETY PROCEDURES

- Wear approved eye protection. - For the wire wheel this means safety glasses and a face shield.
- Dress properly. Do not wear loose clothing or jewelry as they can get caught in moving parts.
- Use a face or dust mask if the buffing operation is dusty.
- Keep work area clean and well lit. Cluttered or dark areas invite accidents.
- Check machine for damaged parts prior to operation. Alert your instructor if parts are damaged.
- Do not use machine if any part(s) are broken or damaged.
- Hold your work against the wheel just below the middle point. If the wheel should grab it, it will throw it down and away from you.
- Buffing can generate a fair amount of heat, so handle your work with care to avoid getting burnt.
- Don't force the buffer/wire wheel. It will do the job better and safer at the feed rate for which it was designed.
- Use a holder when practical. It's safer than using your hand and it keeps hands away from wheel. Always keep hands at least 2 inches from wheels.

## Grinder/Buffer/Wire Wheel Safety Test

Student Name: \_\_\_\_\_

Date: \_\_\_\_\_

	TRUE/FALSE	
1. Wear safety glasses on grinder	T	F
2. Tell teacher if the tool rest is further than 1.5cm from stone	T	F
3. You can grind on the side of stone	T	F
4. Small pieces should not be held with hands, but with pliers	T	F
5. It is fine to grind sheet metal or soft metals like aluminum	T	F
6. Hold your work against the buffing wheel just below middle point	T	F
7. Loose clothing and jewelry is acceptable on these machines	T	F
8. Wear safety glasses and face shield on the wire wheel or buffer	T	F
9. To speed up your work, force your material into the machine	T	F
10. Always ask permission before using the machine	T	F
I have discussed shop safety with the instructor and understand that I need to be careful when working around power tools so nobody gets injured.  Signed: _____	SCORE:    /	



## FORGING & TEMPERING SAFETY

A forge is used to heat metals so they can be reshaped by forging, as well as temper metals to improve their hardness or elasticity by reheating and then cooling it

### Important Parts:

- Gas supply
- Fan motor
- Control panel

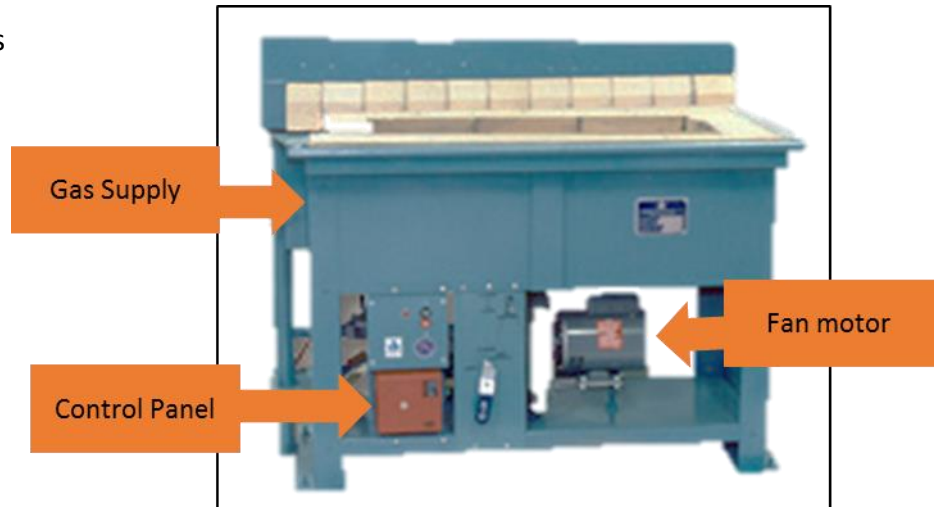

## SAFETY PROCEDURES

- Wear approved eye protection.
- Dress properly. Clothing made of leather, cotton or wool is suitable. Synthetic materials like polyester are flammable - don't wear clothing containing these synthetic fibres. Close-toed footwear and long pants are also required.
- Do not light the furnace unless you have permission. The gas used in a forge is very flammable and a serious accident could result if you don't light it properly.
- Use tongs to handle hot metal items.
- Keep work area clean and well lit. Cluttered or dark areas invite accidents.

## FOUNDRY OVEN

A gas heated furnace used to melt metal for the purpose of casting.

### Important Parts:

- Lid handle
- Gas supply
- Furnace body
- Gas control panel

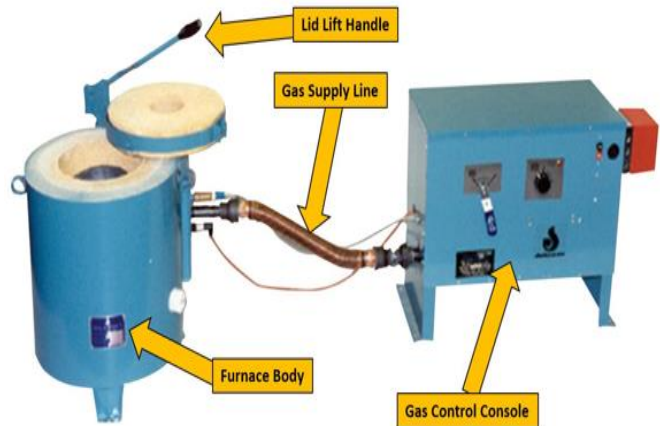

## SAFETY PROCEDURES

- Wear approved eye protection.
- Dress properly. Do not wear loose clothing or jewelry.
- Keep work area clean, well ventilated and well lit. Cluttered or dark areas invite accidents
- Do not light the furnace unless you have permission. The gas used to heat it is very explosive and a serious accident could result from trying to light it incorrectly.
- Preheat cold metal before adding it to a pot of molten metal to reduce its moisture content. If you were to drop cold metal into molten metal, the intense heat could vaporize the moisture instantly and cause an explosion of molten metal.
- Wear a mesh facemask, burn-proof gloves and leggings when pouring a cast. The molten metal you are working with will quickly melt or burn through standard safety gear so you need special protective clothing that can withstand extremely high heat.
- Stand to the side as you pour a casting. Again, moisture is the problem. If steam gets trapped inside a tightly packed mold, the resulting pressure could blow the mold apart.
- Put the flask on a bed of sand or fire bricks while you pour the casting. Concrete has moisture in it, so if you accidentally drop liquid metal on it, the concrete could fracture and send chips flying unpredictably.
- Castings take a long time to cool down. Use extreme caution when opening up a recent casting to avoid burning yourself. Freshly poured castings must be marked "HOT."

## Foundry/Forge Safety Test

Student Name: \_\_\_\_\_

Date: \_\_\_\_\_

	TRUE/FALSE	
1. Wear a mesh facemask, burn-proof gloves, leather jacket, appropriate foot wear and leggings when pouring molten metal	T	F
2. Polyester clothing is acceptable when working in foundry/forge area	T	F
3. Only the teacher is permitted to turn equipment on	T	F
4. Preheat cold metal before adding to melting pot	T	F
5. Moisture is a good thing to help in the melting process	T	F
6. All people working in foundry/forge area should be appropriately dressed	T	F
7. You must ask teacher permission before working in foundry/forge area	T	F
8. Mark castings with "hot" after pouring	T	F
9. Be aware of the material pathway when removing heated steel from the forge	T	F
10. Clean working area prior to starting work in the foundry/forge area	T	F
I have discussed shop safety with the instructor and understand that I need to be careful when working around power tools so nobody gets injured.		
Signed: _____		SCORE:    /

## METAL CUT OFF SAW

An abrasive saw, also known as a cut-off saw or chop saw, is a power tool which is typically used to cut metals. The cutting action is performed by an abrasive disc, similar to a thin grinding wheel.

### Important Parts:

- Guard
- Material clamp
- Fence

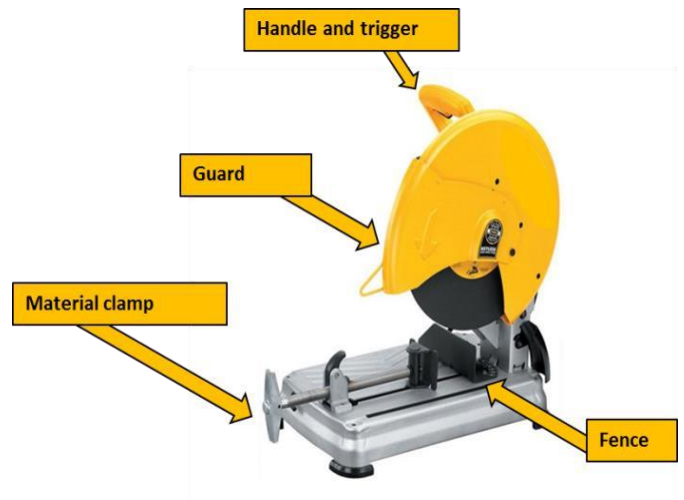

## SAFETY PROCEDURES

- Wear approved eye protection, safety glasses and a face shield.
- Wear approved hearing protection due to the extreme noise this tool generates.
- Ensure all loose clothing and hair are secured.
- Inspect the cut off wheel for chips and cracks.
- Use the vice to securely clamp the work and properly support the over-hanging portion of the work piece level with the base of the machine.
- Allow the machine to reach full speed before contacting the work piece.
- Ease the abrasive disc against the work piece when starting to cut.
- After finishing the cut, release the switch, hold the saw arm down and wait for the disc to stop before removing work or off-cut piece.
- Before making any adjustments, disconnect the plug from the power source and bring the machine to a complete standstill.
- Do not have any part of your body in line with the path of the abrasive disc.

## Metal Cut Off Saw/Angle Grinder Safety Test

Student Name: \_\_\_\_\_

Date: \_\_\_\_\_

	TRUE/FALSE	
1. Safety glasses and face shield is always necessary on these tools	T	F
2. Inspect abrasive disc for cracks or loose parts prior to use	T	F
3. Guards are not required on these tools	T	F
4. Sparks are of no concern when using these tools	T	F
5. Make sure materials are either clamped or secure	T	F
6. Hearing protection is required	T	F
7. Remove work from cut off saw before the blade stops rotating	T	F
8. Try to put your body in line with the path of the abrasive disc	T	F
9. Use a light pressure to start a cut	T	F
10. Ask permission before using the tool	T	F
I have discussed shop safety with the instructor and understand that I need to be careful when working around power tools so nobody gets injured.  <b>Signed:</b> _____	<b>SCORE:</b> /	

## METAL LATHE

A large lathe specifically designed for precision machining. These machine tools remove material from a rotating work piece through typically linear movements of various cutting tools.

### Important parts:

- Headstock
- Tail stock
- Chuck
- Motor lever
- Saddle
- Tool post

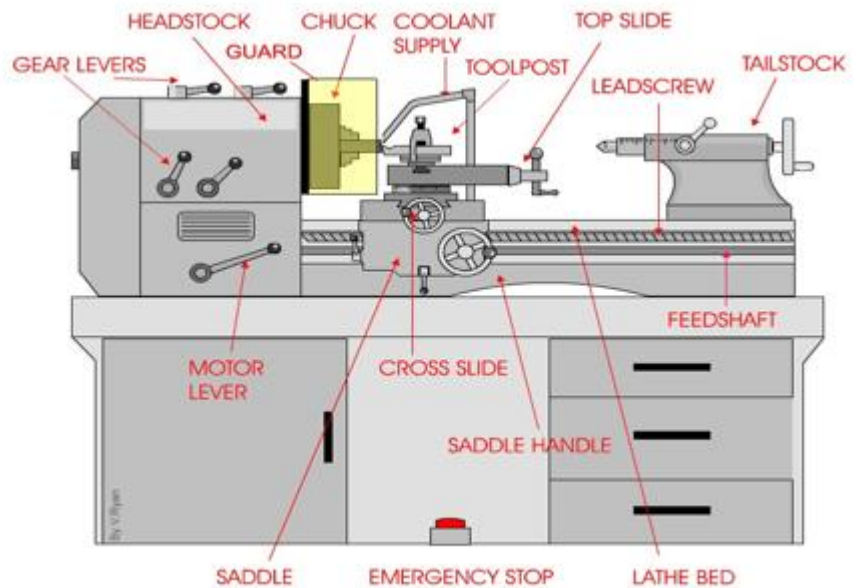

## SAFETY PROCEDURES

- Safety glasses must be worn at all times. Long hair must be tied back; rings and jewelry must be removed. Close fitting/protective clothing must be worn. Gloves must not be worn when using this machine.
- Check that the job is clamped tight in the chuck then remove the chuck key before starting the lathe.
- Remove all tools from the bed and slides of the machine.
- Ensure correct speed for machining process is selected.
- Before making adjustments or measurements switch off and bring the machine to a complete standstill.
- Do not attempt to slow/stop the chuck or revolving work by hand.
- Avoid letting swarf build up on the tool or job. Stop the machine and remove it.
- Material that extends more than twice its diameter out of the chuck should be supported on the tailstock.
- Use extreme caution if your stock extends through the headstock end. Many accidents have resulted when an operator, while concentrating on the cut, failed to notice the end of the stock whip around. Others have been injured by trying to steady the protruding end (don't do this), or by bumping into it accidentally as they pass by.

### Hazards to watch out for:

- Flying objects - chuck key left in chuck
- Cutting tool injury when cleaning, filing or polishing
- Rotating machine parts - entanglement
- Metal splinters/swarf

## Metal Lathe Safety Test

Student Name: \_\_\_\_\_

Date: \_\_\_\_\_

	TRUE/FALSE	
1. Safety glasses must be worn at all times	T	F
2. Gloves should be worn when using this machine	T	F
3. Loose clothing and jewelry is acceptable while working on the lathe	T	F
4. The chuck key must never be left in the chuck	T	F
5. Use your hand to slow down the chuck so that you can leave the machine quicker	T	F
6. Use extreme caution if your stock sticks through the headstock end	T	F
7. Do not use your hand to remove swarf	T	F
8. Long hair must be tied back	T	F
9. The bed and slide area is a good place to store you tools	T	F
10. Ask permission to use the machine before using	T	F
I have discussed shop safety with the instructor and understand that I need to be careful when working around power tools so nobody gets injured.  Signed: _____	SCORE:    /	

## OXY /ACETYLENE TORCH

Oxy-Acetylene Welding or Oxy-Acetylene Cutting are processes that use Acetylene Gas and Oxygen to weld and or cut metals.

### Important Parts:

- Regulators
- Torch valves
- Cylinder Valves
- Hoses
- Adjusting screw

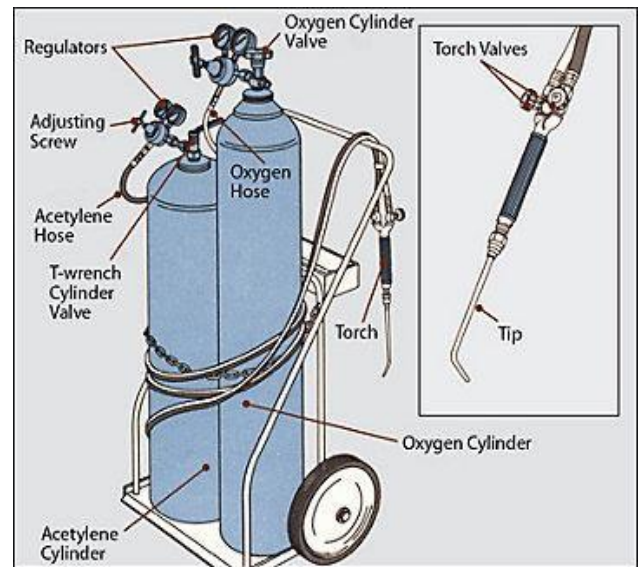

## SAFETY PROCEDURES

- You must be trained and authorized before you are allowed to use the oxy-acetylene equipment. Always wear leather gloves and approved welding goggles. Make sure anyone who watches or helps also wears proper protective gear.
- Ensure acetylene cylinders are kept upright at all time.
- Always watch for gas leaks by listening to or brushing the connections with soapy water.
- Be aware of the location of the hoses are all times. Open the acetylene valve slightly and light the torch with a flint lighter. Continue to slowly open the acetylene valve until the flame no longer produces soot. Slowly open the oxygen valve until a neutral flame is produced.
- Make sure your work area has effective local ventilation. Galvanized metal, brass or bronze emit toxic fumes when heated. Respiratory protection may also be required. Start the fume extraction unit before beginning to weld.
- Purge with acetylene. Light the acetylene first with a striker (not matches), then add oxygen. This will ensure that there is no mixed gas in the lines that could burn back up inside.
- Mark recently welded work "Hot" or guard it to prevent it from being contacted. Make a habit of feeling for heat before you grab hold of anything. Vices, bricks, or tools can give a serious burn even though they may not look hot.
- The oxy-acetylene flame burns at about 3000°C. Always watch where you put the tip and only set the torch down in a proper holder so it doesn't fall.



## Oxy/Acetylene Safety Test

Student Name: \_\_\_\_\_

Date: \_\_\_\_\_

	TRUE/FALSE	
1. Ask teacher permission before using Oxy/Acetylene equipment	T	F
2. Always wear leather gloves and approved welding goggles	T	F
3. Ensure anyone who watches or helps also wears proper protective gear	T	F
4. Leaky hoses and connections are acceptable when using gear	T	F
5. You should purge acetylene line prior to using	T	F
6. Ventilation for fumes is not a concern with Oxy/Acetylene processes	T	F
7. Mark recently welded or cut work with "Hot"	T	F
8. When finished, leave regulators on for the next person	T	F
9. When finished, close acetylene blowpipe first	T	F
10. When finished, all gasses, oxygen and acetylene, should have been bleed from lines	T	F
<p>I have discussed shop safety with the instructor and understand that I need to be careful when working around power tools so nobody gets injured.</p> <p>Signed: _____</p>	SCORE:    /	

## PLASMA TORCH

A plasma cutter is a metal fabrication tool that uses electricity and compressed air to cut through a variety of metal types, shapes and sizes.

### Important parts:

- Control panel
- Torch handle
- Material ground clamp
- Rear air & electrical connections



## SAFETY PROCEDURES

- Wear approved shaded eye protection, shade 5 or darker.
- Use protective screens. Warn others nearby before cutting.
- Proper ventilation must be used.
- Ensure compressed air is on and set at the correct pressure (75psi).
- Do not cut in wet areas.
- Always ground your work or the table, cut over the cutting table.
- Drag the tip along metal at 90 degrees, ensure sparks go right
- Don't pull trigger until the torch is next to the metal and you are ready to cut

## Welding/Plasma Torch Safety Test

Student Name: \_\_\_\_\_

Date: \_\_\_\_\_

	TRUE/FALSE	
1. Always wear approved welding helmets with a #10 lens or darker	T	F
2. Safety glasses are not required when chipping or grinding welds	T	F
3. Mark metal that is not hot, with a large C to let others know it is cold	T	F
4. Never weld a container that has held flammables	T	F
5. It is fine to weld in an open area where others are exposed to your welding flash	T	F
6. Ensure proper ventilation	T	F
7. Do not weld or cut in wet areas	T	F
8. The plasma torch requires any pressure above 90psi	T	F
9. Always ground your work	T	F
10. Ask teacher permission before using welding/plasma equipment	T	F
I have discussed shop safety with the instructor and understand that I need to be careful when working around power tools so nobody gets injured.	<b>SCORE:    /</b>	
Signed: _____		

## SAND/BEAD (MEDIA) BLASTER

A media blaster is a cabinet that uses compressed air to force media (sand, glass bead, walnut shells, etc.) against a materials surface in an effort to clean and/or finish the surface.

### Important Parts:

- Air line connection
- Latched access door
- Glove access
- Viewing window

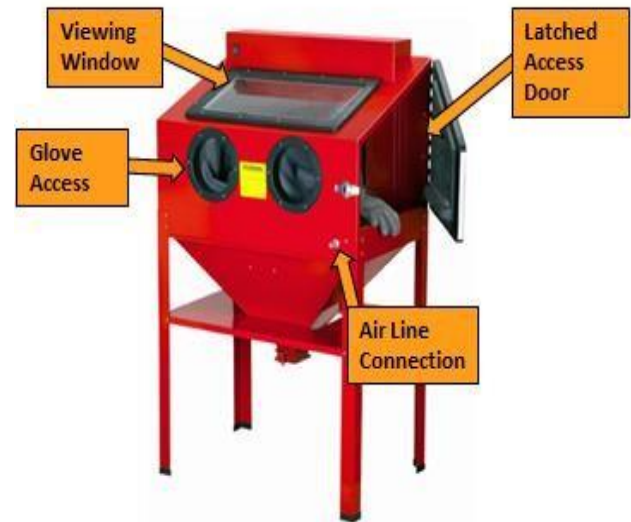

## SAFETY PROCEDURES

- Before blasting, turn on the vacuum for ventilation. When blasting, ventilation must be on. If media starts coming out of the machine, or if the vacuum stops working, you must stop blasting immediately.
- Check the gloves for damage, rips, tears or punctures. You can do this easily by closing the door and turning on the vacuum as the suction will inflate the gloves and you will be able to feel air move past the opening for your hands.
- Always check the media blaster nozzle for wear. If the nozzle looks worn out, tell your teacher.
- Never spray media on your gloved hand. When you are starting your blasting job, always start the flow of media away from your material and hand holding said material and bring the material to the media. This will make sure you do not spray media on your hand
- Hold small objects with pliers or weld them to larger pieces of material so you do not spray media on your hands.
- Do not spray media on the glass or light

# MILLING MACHINE

The milling machine uses a variety of rotary cutters to remove material from a workpiece by advancing the cutter into the workpiece in a specific direction. The cutter may also be held at an angle relative to the axis of the

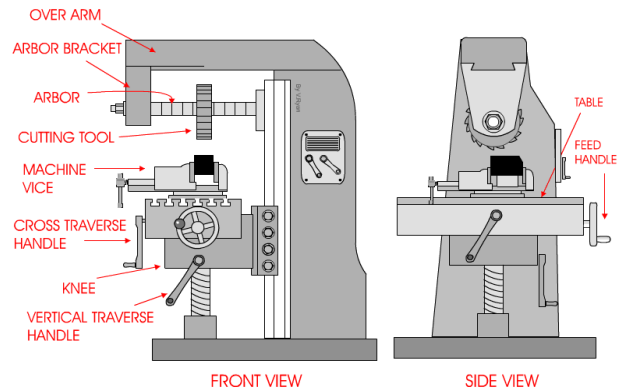

## Important parts:

- Table feed handle
- Cutting tool
- Cross traverse handle
- Vertical traverse handle
- Machining vice
- Table
- Over arm

## SAFETY PROCEDURES

- Wear approved eye protection. Dress properly. Do not wear loose clothing or jewelry.
- Check machine for damaged parts prior to operation. Alert your instructor if parts are damaged.
- Locate and ensure you are familiar with the operation of the ON/OFF starter and E-Stop (if fitted).
- Move table as far as possible from cutter while setting up work to avoid injuring your hands. Mount work in a vise that is bolted or held magnetically to the table.
- Check that machine guards are in position where applicable/suitable.
- Before starting, make sure that handles on all feed screws are in neutral.
- Make sure the power is off before changing cutters. Hold milling cutters with a cloth to avoid being cut when handling them.
- Never leave the machine running unattended.
- Keep hands at least 30 cm (12 in.) from a revolving cutter. Also be sure to keep brushes and rags away from the revolving milling cutter.
- Use a vacuum, brush or rake to remove cuttings only after the cutters have stopped moving.
- Keep floor around the milling machine free of oil and grease.

## Milling Machine Safety Test

Student Name: \_\_\_\_\_

Date: \_\_\_\_\_

	TRUE/FALSE	
1. Eye protection is mandatory at all times	T	F
2. Feed screws should be engaged when starting the machine	T	F
3. Check cutting bits for sharpness with soft part of your index finger	T	F
4. It is all right to leave this machine running while un-attended	T	F
5. Brush off shavings with your hands once the machine has stopped	T	F
6. Clean floor around milling machine free of cutting fluid	T	F
7. No loose clothing or long hair	T	F
8. Hold materials being cut firmly with left hand while milling the part	T	F
9. Use a cloth or glove to hold cutters when installing in machine	T	F
10. Always ask teacher permission before use	T	F
I have discussed shop safety with the instructor and understand that I need to be careful when working around power tools so nobody gets injured.  Signed: _____	SCORE:    /	

## POWDER COATING

A finishing process designed to coat the product in epoxy or polymer, once heated the coating provides a fused protective coating on the finished piece.

### Important Parts:

- High voltage multiplier
- Powder feed line
- High voltage electrode
- Low voltage cable

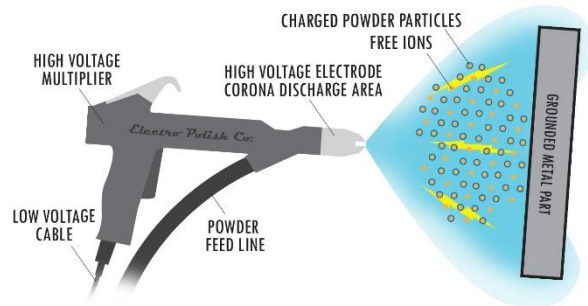

## SAFETY PROCEDURES

- Wear approved eye protection. Long hair should be tied back and appropriate closed toed shoes worn.
- Use approved particulate mask.
- Turn on the ventilation fan prior to spraying your item(s).
- Have heat-resistant gloves ready to move your item(s) to and from the oven.

## MIG & TIG WELDING

- **MIG welding** is a welding process where a continuous, consumable wire is fed through a welding gun and into the weld pool, joining the two base materials together. A shielding gas is also sent through the welding gun to protect the weld pool from contamination. MIG stands for "Metal Inert Gas."
- **TIG welding**, is a welding process that uses a non-consumable tungsten electrode to produce the weld. The tungsten and weld puddle are protected and cooled with an inert gas, typically argon.

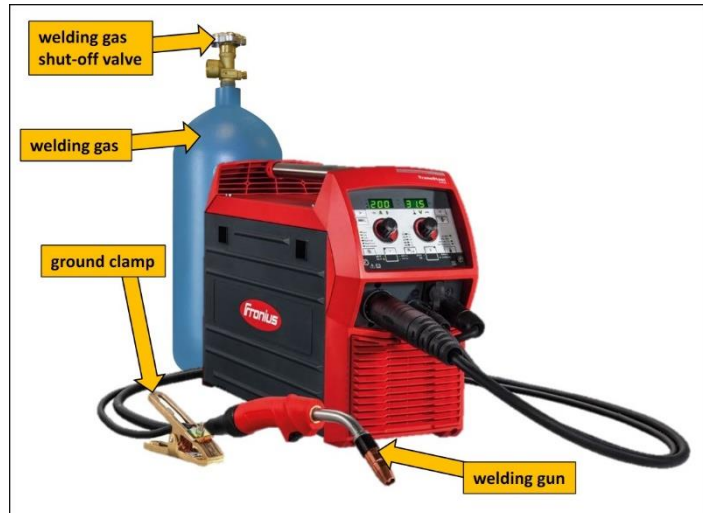

## SAFETY PROCEDURES

- The light from the welding flash is so bright that it can burn your skin and eyes. Safety glasses must be worn under a protective welding helmet with the correct grade of UV filter lens for MIG welding.
- Close fitting protective clothing or overalls and a leather apron must be worn. Overalls must be made of cotton not synthetic materials such as polyester.
- Close-toed footwear must be worn. Welding gloves must be used - ensure gloves don't have holes in them.
- Rings or jewellery should NOT be worn when using any welding equipment.
- Protect others from splatter, flash, and glare with protective screens or barriers.
- Be sure to avoid accidental UV welding flash to the skin or eyes.
- Keep work area clean and well lit. Cluttered or dark areas invite accidents.
- Ensure the welding area is well ventilated and fume hood fan is turned on.
- Ground the work or metal to be welded to a good electrical ground.
- Shut off shielding gas supply when the welder is not being used.
- Never leave the welder running unattended - turn it off if you leave the work area.



## CNC Plasma Torch/MIG & TIG Safety Test

Student Name: \_\_\_\_\_

Date: \_\_\_\_\_

	TRUE/FALSE	
1. Always wear approved welding helmets with a #10 lens or darker for Arc Welding, or approved UV filter lens for MIG Welding	T	F
2. Safety glasses are not required when chipping or grinding welds	T	F
3. Mark metal that is not hot, with a large C to let others know it is cold	T	F
4. Never weld a container that has held flammables	T	F
5. It is fine to weld in an open area where others are exposed to your welding flash	T	F
6. Ensure proper ventilation	T	F
7. Do not weld or cut in wet areas	T	F
8. The plasma torch requires any pressure above 90psi	T	F
9. Always ground your work	T	F
10. Ask teacher permission before using welding/plasma equipment	T	F
I have discussed shop safety with the instructor and understand that I need to be careful when working around power tools so nobody gets injured.  Signed: _____	SCORE:    /	

## SPIN CASTER

A manually operated machine that uses centrifugal force to “throw” molten materials such as gold or silver into a rubber mold. Used in Jewelry making.

### Important parts:

- Crucible slide lever
- Silica crucible
- Investment flask
- Counter balance weight
- Flask receiver assembly
- Winding/Locking knob
- Safety shell
- Mounting base

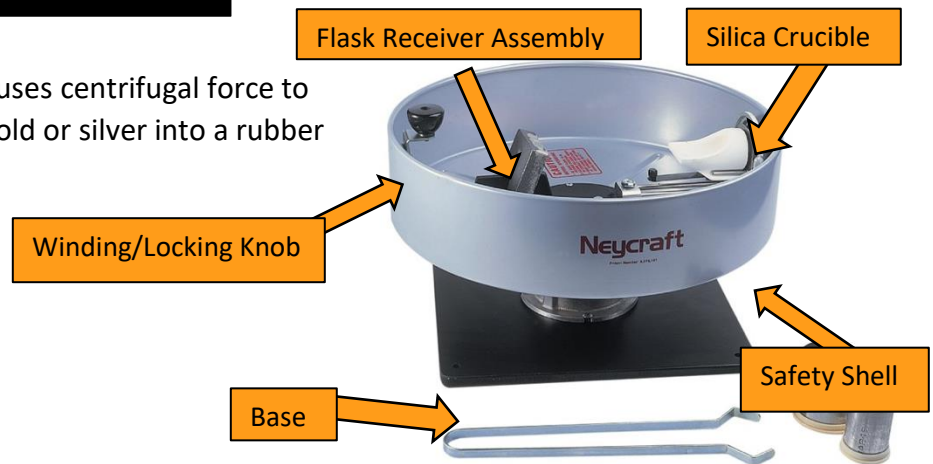

## SAFETY PROCEDURES

- Wear approved eye protection. Ensure long hair is tied back, all jewelry is removed, and that you are wearing closed toed shoes.
- Spin caster should be mounted securely to a table top or bench surface.
- The safety shell should be intact and in place at all times. Damaged or broken shells should be replaced.
- Make sure the area is free of debris and contaminants, this will ensure a clean casting.
- Before beginning make sure all parts are in good working order and move freely as designed.
- The crucible should be checked to ensure it is secured into place properly.
- Once the caster has been released via the locking knob, keep hands away from the safety shell, until it has come to a complete stop.

## PROPANE/JEWELERS TORCH

A small hand held torch used for jewelry making and small project work. Tips can be changed to provide different heat distribution .

### Important parts:

- Tank
- Torch head
- Torch valve



## SAFETY PROCEDURES

- Wear approved eye protection. Ensure long hair is tied back, all jewelry is removed, and that you are wearing long pants, gloves and closed toed shoes.
- Make sure your work area is clean and free of debris and remove any flammable materials.
- Make sure your work area has effective local ventilation.
- Do not light the torch unless you have permission. The gas used is very explosive and a serious accident could result from someone trying to light it if they didn't really know how.
- You must use a striker to light the torch.
- Turn the torch valve counter clockwise to begin the release of propane. Holding the striker to the side of the torch head, strike to ignite the propane.
- The tip is HOT and should not be touched.
- Using the torch valve adjust to desired flame size.
- Make a habit of feeling for heat before you grab hold of anything. Vices, bricks, or tools can give a serious burn even though they may not look hot.
- When finished, turn off the torch valve completely.

## SOLDERING PENCIL / IRON

A hand-operated tool with a tip that can reach temperatures of 425°C (800°F). Used to melt solder to join metals together without melting the base material.

### Important parts:

- Tip
- Body
- Cord / Plug in



## SAFETY PROCEDURES

- Wear approved eye protection. Ensure long hair is tied back, all jewelry is removed, and you are wearing closed toed shoes. \*It is recommended that long pants be worn as well\*
- When you plug in the soldering pencil/iron make sure the cord does not touch the tip.
- The tip is HOT and should not be touched.
- Always place the soldering pencil in the holder – NOT ON THE DESK/TABLE
- Use proper ventilation or fume extraction. Keep face 1- 2 feet away from your work. Never breathe in the fumes.
- Melted solder can burn through clothes and your skin. Never solder upside down
  - \*\*\* Hold the items to be soldered upside down.\*\*\*
- Unplug the unit by grasping the plug, NOT the cord.
- Put your soldering pencil/iron away in the appropriate location, ensuring the tip does not touch the cord. Soldering pencils stay hot for a long time after they are unplugged.

## Soldering Pencil / Wood Burning Safety Test

Student Name: \_\_\_\_\_

Date: \_\_\_\_\_

	TRUE/FALSE	
1. Eye protection should always be used when using the soldering pencil or wood burning tool.	T	F
2. Tuck in, or remove all loose clothing and jewelry that could get in the way.	T	F
3. Long hair does not need to be tied back or protected when soldering.	T	F
4. Always place the Soldering pencil/Wood burning tool in the holder – NOT ON THE DESK/TABLE	T	F
5. The whole soldering pencil gets hot.	T	F
6. Pull the cord to unplug the soldering pencil/ wood burning tool	T	F
7. Pencils should be put away properly, ensuring the tip will not make contact with anything.	T	F
I have discussed shop safety with the instructor and understand that I need to be careful when working around power tools so nobody gets injured.  Signed: _____	SCORE:    /	

## DISC/BELT SANDER

A metal belt/disc sander is a stationary machine that is generally used to rough sand material for final finishing of metalworking projects.

### Important Parts:

- Work table
- Disc surface
- Belt surface
- Work table angle adjustment



### SAFETY PROCEDURES

- Wear approved eye protection, long hair should be tied back and all jewelry removed.
- When using the belt/disc sander, always keep your metal flat on the work table.
- If you wish to sand on an angle, always use a miter gauge or tilt the table.
- Never use material thinner than ½" on the belt/disc sander as it may pull your material into the belt/disc.
- Sand side to side so that you wear the belt evenly. If you stay in one spot too long you will damage the belt and it may break.
- When sanding on the disc, always sand on side of the disc turning down towards the work table. Do not sand on the side with upward motion as the disc will lift your material and could throw your material into the air.
- When sanding small parts always use locking pliers or affix the part to something larger to protect your hands
- Never wear gloves on the belt/disc sander. If you get your fingers too close the gloves will pull your hands in. Cool the material off in the quench pot if it gets hot

**Disc/Belt Sander Safety Test**

Student Name: \_\_\_\_\_

Date: \_\_\_\_\_

	<b>TRUE/FALSE</b>	
1. Sanding can be safely done on either the left or right side of the rotating disc.	<b>T</b>	<b>F</b>
2. You can use the disc/belt or spindle sander even if the sanding disc/belt is damaged.	<b>T</b>	<b>F</b>
3. Your metal must be held flat against the table. You cannot lift it off the table otherwise you could get injured.	<b>T</b>	<b>F</b>
4. You may make adjustments to the table while the machine is running to get the correct angle you want.	<b>T</b>	<b>F</b>
5. Two people can work on the machine at the same time.	<b>T</b>	<b>F</b>
6. Before I start the machine, I should check the angle of the table to make sure it is correct.	<b>T</b>	<b>F</b>
7. I can leave the machine as soon as I turn it off.	<b>T</b>	<b>F</b>
8. Hands and fingers should be no closer than 2" (5cm) to the moving abrasive.	<b>T</b>	<b>F</b>
9. Always check with the teacher if you plan any special operations with the disc/belt sander	<b>T</b>	<b>F</b>
10. If you are changing the abrasive disc or belt, make sure the machine is off and the power is disconnected.	<b>T</b>	<b>F</b>
I have discussed shop safety with the instructor and understand that I need to be careful when working around power tools so nobody gets injured.  <b>Signed:</b> _____	<b>SCORE:</b> /	

## BEVERLEY SHEER

A hand-operated piece of equipment that has two blades. One blade is stationary on the bottom of the machine and the other is attached to the handle that, when pulled down, shears the metal where the blades meet.

### Important parts:

- Upper blade
- Lower blade
- Handle

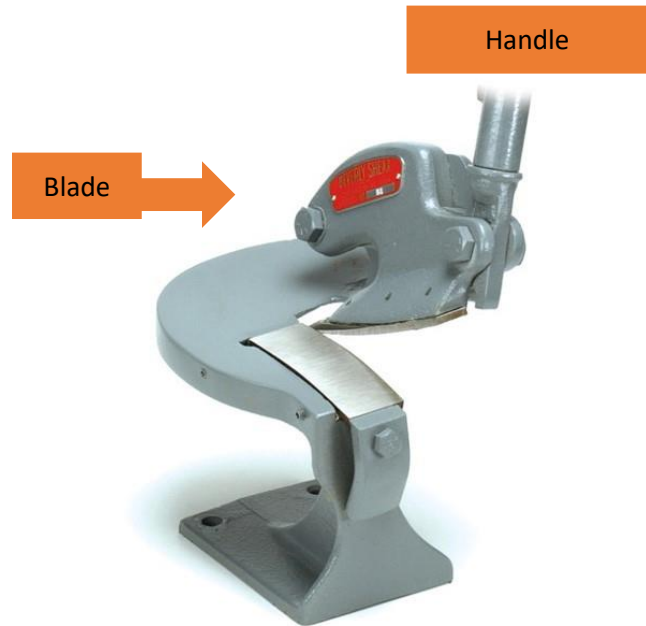

## SAFETY PROCEDURES

- Wear approved eye protection. Ensure long hair is tied back, all jewelry is removed, and that you are wearing closed toed shoes.
- Check equipment for damaged parts and report any issues to your instructor. Never use a dull or broken blade.
- The shear is a dangerous tool as you can crush or sever your fingers. NEVER place your fingers under or near the blade area.
- Never force the tool or attachments to do work they are not designed for.
- To prevent any chance of injury the beverly shear is a one person tool.
- Always lay the material to be cut flat on the bed of shear, and start the cut at the back of the blade.



## SQUARING FOOT SHEER

A foot-controlled machine used to cut sheet metal stock. Designed for larger square cuts and trimming.

### Important parts:

- Extension arm
- Foot pedal
- Side gauge
- Hold down & Guard
- Blade

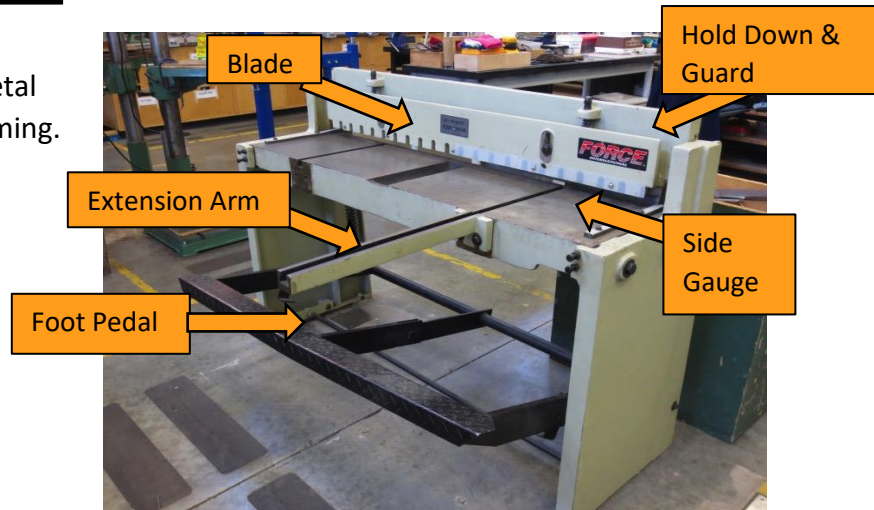

## SAFETY PROCEDURES

- Wear approved eye protection. Ensure long hair is tied back, all jewelry is removed, and that you are wearing closed toed shoes.
- The sheet metal shear is a dangerous tool as you can crush or sever your fingers. Never place your fingers under or behind the safety guard.
- To prevent any chance of injury the sheet metal squaring shear is a one person tool. No one should operate the foot pedal for you.
- Line up your material using the side gauges and ensure your hands/fingers are away from the guard and blade.
- Be mindful of the placement of your feet while operating.

## Sheet Metal Tool Safety Test

Student Name: \_\_\_\_\_

Date: \_\_\_\_\_

	TRUE/FALSE	
1. Wear approved eye protection.	T	F
2. It is important to check for broken or damaged blades or parts.	T	F
3. Keep fingers away from all cutting/bending or pinch point areas.	T	F
4. Ensure handles and counterweights have a clear path of movement, free of obstacles.	T	F
5. It is completely safe to use sheet metal tools with multiple people.	T	F
6. Line up your material using the guides on the machine.	T	F
7. It is not important to know where your feet are placed when using sheet metal tools.	T	F
I have discussed shop safety with the instructor and understand that I need to be careful when working around power tools so nobody gets injured.	SCORE:    /	
Signed: _____		

## DRILL PRESS (METAL)

The drill press is used for drilling large holes, for drilling holes perfectly perpendicular or parallel to the stock, or for drilling multiple holes to the same depth.

### Important Parts:

- Depth stop
- Chuck
- Feed crank
- Table

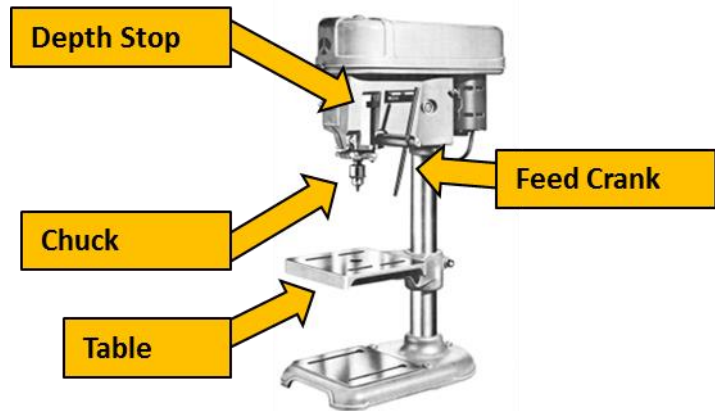

## SAFETY PROCEDURES

- Wear approved eye protection.
- Be sure to tie back long hair before using the drill press. You don't want your hair getting caught in the spinning chuck.
- Tuck in or remove all loose clothing (hoodie strings, jewellery) that could get caught in the drill press.
- The material you intend to drill must be secured in a drill vice or clamped down to the drill press table. This will prevent it from spinning around and hurting you if the drill bit were to catch.
- The chuck on the drill press spins in a clockwise rotation. If drilling into a long work piece, rest one end of the wood against the left hand side of the drill press column to avoid getting hit by the stock if it somehow catches the bit.
- Set an appropriate drill speed for the drill bit (large bits should spin slower, smaller bits should spin faster)
- Make sure the chuck key is out of the chuck every time you go to start the drill.
- Set up your operation to avoid drilling into the vice or table. Put some scrap wood under your work or position the vice so that the bit won't drill it as it passes through the work piece.
- When drilling, advance the drill bit with an even and moderate pressure and reduce pressure as the bit breaks through the bottom of your work piece (this prevents breakout and the chance of the bit catching at the bottom of the hole).

## Drill Press Safety Test

Student Name: \_\_\_\_\_

Date: \_\_\_\_\_

	TRUE/FALSE	
1. Eye protection should always be used when using the drill press.	<b>T</b>	<b>F</b>
2. Tuck in, or remove all loose clothing and jewelry that could get caught in the drill press.	<b>T</b>	<b>F</b>
3. Long hair does not need to be tied back or protected when drilling.	<b>T</b>	<b>F</b>
4. The material you intend to drill must be secured in a drill vice, or clamped down to the drill press table.	<b>T</b>	<b>F</b>
5. It is important to try and position your material and the table, so that the drill bit is directly over the clearance hole.	<b>T</b>	<b>F</b>
6. Make sure the chuck key is out of the chuck every time you go to start the drill.	<b>T</b>	<b>F</b>
7. Always set the drill to an appropriate speed for the size of the bit being used.	<b>T</b>	<b>F</b>
8. Always feed the drill bit into the material as fast as possible when drilling.	<b>T</b>	<b>F</b>
9. The chuck key must be removed after installing or removing the drill bit.	<b>T</b>	<b>F</b>
10. If you drill deep holes, you should withdraw the bit frequently to prevent clogging and burning.	<b>T</b>	<b>F</b>
I have discussed shop safety with the instructor and understand that I need to be careful when working around power tools so nobody gets injured.  <b>Signed:</b> _____	<b>SCORE:</b> /	

## SPOT WELDER

Resistance spot welding is a process where contacting metal surface points are joined by the heat obtained from resistance to electric current.

### Important Parts:

- Welding tips
- Foot pedal

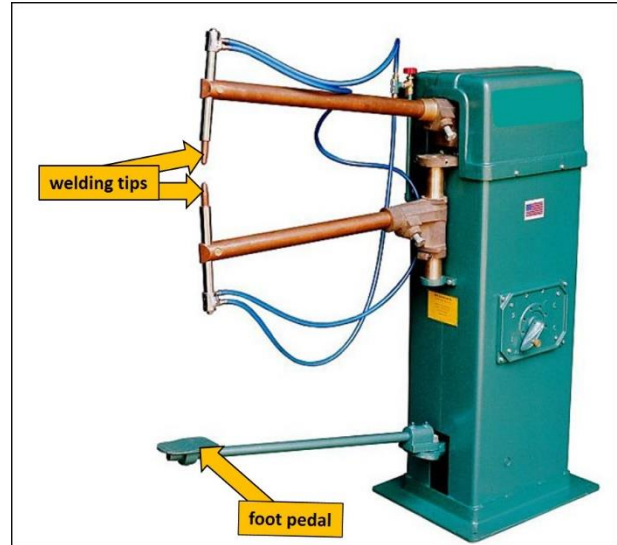

## SAFETY PROCEDURES

- Wear approved eye protection as sparks will fly from the area being welded.
- Dress properly. Do not wear loose clothing or jewelry. Long pants are required to cover the entire leg.
- Closed-toe footwear is required.
- Keep work area clean and well lit. Cluttered or dark areas invite accidents.
- Use leather gloves to position and hold the hot metal parts being spot welded.
- Keep your fingers away from the welder's tips as they can burn you or pinch/crush your fingers.
- Turn off the spot welder once you are finished using it.

## RIGHT ANGLE GRINDER

An angle grinder, also known as a side grinder or disc grinder, is a handheld power tool used for grinding (abrasive cutting) and polishing. Typically angle grinders have an adjustable guard and a side-handle for two-handed operation.

### Important Parts:

- Handle
- Abrasive disk
- Trigger



## SAFETY PROCEDURES

- Wear safety glasses, a face shield and hearing protection at all times when using a grinder.
- Inspect the grinder prior to use to ensure there are no cracks in the abrasive disc.
- Check there are no flammables in the area before grinding.
- Secure the stock you are going to grind so that it does not move around. Unless the material is large and very steady, you should put it in a vice or clamp it to a workbench to prevent the grinder from pushing it aside.
- Grind with moderate pressure only. Excessive pressure generates excessive heat and puts unnecessary strain on the grinding disk, the motor and the operator.
- Grinders shoot out a stream of cool sparks. Be conscious of where the sparks are going and take care to avoid endangering yourself and others.
- Any time you are grinding, things will get hot. Make it a habit to test things for heat before you grab onto them.
- Never remove the guard from the grinder
- If you move the handle from one side to another, move the guard to protect your hand.
- When using a cutting disk remember to make sure that you do not change the angle of the cut once you have started. You are committed to that angle once you begin. Changing it will shatter the disk.
- Do not start the grinder with the disk touching anything.

## CNC PLASMA CUTTER

Plasma cutting is a process that cuts through metals using an accelerated jet of hot plasma. A CNC plasma machine moves the torch in a path directed by a computer. The term “CNC” refers to “Computer Numerical Control”, which means that a computer is used to direct the machine’s motion based on numerical codes in a program.



### SAFETY PROCEDURES

- Plasma arc rays can injure your eyes and burn your skin. The plasma arc process produces very bright ultraviolet and infrared rays. These rays will damage your eyes and burn your skin if you are not properly protected.
- Use safety glasses and a shield with the proper filter and cover plates to protect your eyes from sparks and the rays of the arc.
- Use suitable clothing including flame-resistant gloves to protect your skin and that of your helpers from the arc rays.
- Keep work area clean and well lit. Cluttered or dark areas invite accidents.
- Protect other people working in the area with non-flammable screening and/or warn them not to watch the arc or expose themselves to the arc rays or to hot spatter or metal.
- Plasma cutting can produce fumes and gases hazardous to your health. Avoid breathing these fumes and gases. When cutting, keep your head out of the fumes. Ensure there is adequate ventilation and turn on the fume hood fan.
- Additional venting and extraction precautions are required when cutting galvanized steel or materials containing or coated with any of the following: Antimony, Arsenic, Barium, Beryllium, Cadmium, Chromium, Cobalt, Copper, Lead, Manganese, Mercury, Nickel, Selenium, Silver, Vanadium
- Do not wear loose clothing or jewelry. Loose clothing can get caught in moving parts.
- Have a fire extinguisher readily available. Be sure there are no combustible or flammable materials in the workplace.
- Keep your body away from nozzle and plasma arc.

## KILN/ BURNOUT OVEN

A thermally insulated chamber that can reach high temperatures needed to melt glass, ceramics and other products. Used in a variety of processes including jewelry making.

### Important Parts:

- Control panel
- Door
- Element
- ON/OFF Switch

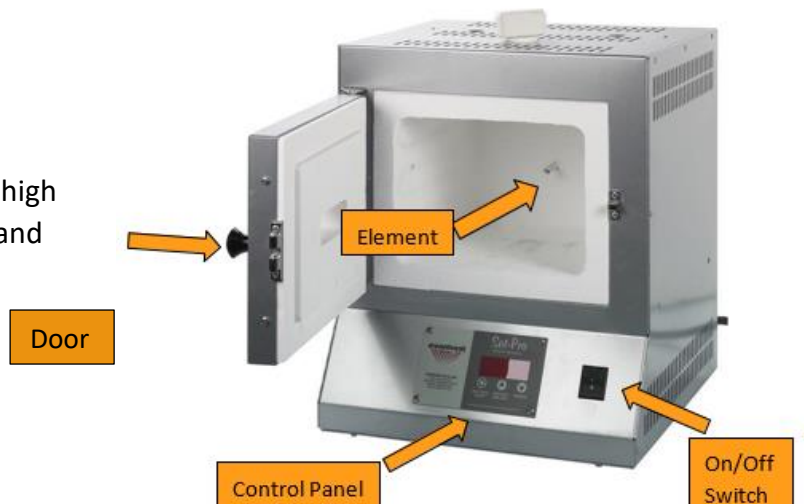

## SAFETY PROCEDURES

- Wear approved eye protection. Ensure long hair is tied back, all jewelry is removed, and that you are wearing closed toed shoes.
- The Oven/Kiln should be installed at least 12" away from any wall, equipment or combustible surface.
- Dangerous voltage – Do not touch the heating elements.
- Disconnect the furnace before servicing in any way.
- Do not open the oven door until the oven has cooled completely, and all switches are off.
- While the Oven/Kiln is on do not touch the sides.
- Unplug the Oven when not in use.
- When placing objects in the oven, be sure to keep them away from the elements and temperature gauge. Objects should NOT touch the interior walls of the oven.
- Using kiln shelves or bricks to raise project work to the center of the oven will result in even heat distribution around the project.
- Elements should be replaced immediately if they are broken, cracked or damaged.



# **AUTOMOTIVE**

## Automotive Shop Safety

Topic	Notes	Student Information
<b>Batteries</b>	<p>Sulphuric acid is very corrosive. Personal protective clothing requirements are goggles and/or face shield, gloves, and coveralls and/or apron.</p> <p>Batteries are heavy. Caution students to take care in moving them.</p> <p>A metal tool shorting across battery terminals can get hot very quickly.</p>	<ul style="list-style-type: none"> <li>• Batteries contain sulfuric acid, so wear personal protective equipment and avoid contact with the acid</li> <li>• Battery action produces explosive gas, so take precautions to keep sparks away from batteries, especially when charging</li> <li>• To start charging a battery, connect the leads first, then turn the charger on</li> <li>• To finish charging a battery, turn the charger off, then disconnect the leads</li> <li>• While charging a battery, monitor the temperature; stop charging if the battery gets really hot</li> <li>• Always disconnect the ground cable first</li> <li>• Never attempt to charge or jump start a frozen battery</li> <li>• Never attempt to charge or jump start a maintenance-free battery if the charge indicator shows low electrolyte (clear or yellow)</li> </ul>
<b>Spill Clean-Up</b>	<p>Many absorbent materials are hazardous and contain silica. Use respiratory protection for clean-up, after teaching hours.</p>	
<b>Safety Around Brakes and Clutches</b>	<p>Brake and clutch linings should be asbestos free</p>	<ul style="list-style-type: none"> <li>• Brake and clutch linings may contain asbestos. Follow procedures for safe handling and disposal</li> </ul>
<b>Spray Painting</b>	<p>Do not use paints that contain isocyanates.</p>	

## Automotive Shop Safety (cont.)

Topic	Notes	Student Information
<b>Safety in the Shop</b>	<p>The conditions in a mechanics shop present some hazards not common to other shop settings. Students should be informed of these special circumstances</p> <p>Ensure MSDS sheets are accessible and up to date.</p> <p>Identify appropriate respiratory protection required. Refer to WCB's Breathe Safer manual for further information on respiratory selection, care, use and maintenance.</p> <p>Explain procedures for handling, use, storage, disposal and emergency and spill clean-up of gasoline.</p>	<ul style="list-style-type: none"> <li>• Keep the floor clear to minimize the risk of tripping</li> <li>• Gasoline is very powerful and its vapours are extremely flammable; handle according to safe work procedures</li> <li>• Wipe up all spills and dispose of rags in the identified, covered, metal container</li> <li>• Know where fire extinguishers are and how to use them</li> <li>• Protect your lungs from dust and toxic substances—wear appropriate respiratory protection</li> <li>• Wear goggles and gloves when handling solvents or other caustic chemicals</li> <li>• Protect your ears from continual loud noise</li> </ul>

## Automotive Shop Safety (cont.)

Topic	Notes	Student Information
<b>Safety Around Engines</b>	<p>These points are valid in either a small engine or automotive class.</p> <p>Explain how to check the radiator hose for pressure.</p>	<ul style="list-style-type: none"> <li>• It may be desirable to remove rings, metal watches and bracelets before working on any engine</li> <li>• Keep your hands away from moving parts</li> <li>• Use extreme caution around engine fans which may strike you, fling things at you, start unexpectedly, or catch dangling leads or strings</li> <li>• Avoid touching hot engine parts; never open the radiator on a hot engine</li> <li>• Do not run engines in enclosed, indoor spaces and always guard against carbon monoxide poisoning</li> <li>• Avoid electric shock from battery or ignition systems</li> <li>• Protect your ears from excess engine or shop noise</li> <li>• On small engines, make sure you can't start the engine by moving the crank</li> <li>• After repair, and prior to startup, ensure that engine is safe to start</li> </ul>

## Automotive Shop Safety Test

Student Name: \_\_\_\_\_ Date: \_\_\_\_\_

	TRUE/FALSE	
1. Safety glasses and gloves should be worn when working with solvents and toxic chemicals	<b>T</b>	<b>F</b>
2. Batteries are safe to dispose of in a dumpster	<b>T</b>	<b>F</b>
3. Always disconnect positive cable first when working with batteries	<b>T</b>	<b>F</b>
4. It is not your job to know where a fire extinguisher is in the shop	<b>T</b>	<b>F</b>
5. Keep your hands away from moving parts	<b>T</b>	<b>F</b>
6. It is safe to open a radiator cap once the engine is shut off	<b>T</b>	<b>F</b>
7. Before working on a vehicle make sure it cannot roll, drop or shift and possibly fall on you or pin you	<b>T</b>	<b>F</b>
8. Never start a vehicle unless you are sure no one will be injured by the motion of the engine	<b>T</b>	<b>F</b>
9. Once you have been shown how to use the hoist you do not need to ask permission again	<b>T</b>	<b>F</b>
10. Oily rags can just be thrown in the regular garbage can	<b>T</b>	<b>F</b>
11. You can run an engine if at least one door is open in a shop	<b>T</b>	<b>F</b>
I have discussed shop safety with the instructor and understand that I need to be careful when working around power tools so nobody gets injured.  <b>Signed:</b> _____	<b>SCORE:</b> /	

## VEHICLE & ENGINE SAFETY



### SAFETY PROCEDURES

- Wear approved eye protection. Dress properly. Do not wear loose clothing or jewelry. Loose clothing can get caught in moving parts.
- Keep work area clean and well lit. Cluttered or dark areas invite accidents.
- Before you begin any work on a vehicle, make sure it cannot roll. Put the transmission in park for an automatic transmission, and neutral for a standard transmission. Set the parking brake, remove the keys from ignition and then chock the wheels.
- Use the exhaust extraction system when running an engine in a shop. This prevents people in the shop from inhaling carbon monoxide - a colorless, odorless, potentially deadly gas.
- Never start a vehicle unless you are 100% sure that the motion of the engine will not endanger anyone. Your friend may ask you to crank the engine while they are under the hood - double check to make sure that their hands are clear before you turn the key. If you are under the hood, make sure your friend at the ignition switch knows never to crank it until they are sure you are clear.
- Do not move a vehicle unless you have a class 5 or 7 license and have received authorization from your teacher. Make certain that the motion of the vehicle will not endanger anyone. Look around carefully, honk the horn, wait, and start moving slowly. Give anyone crouching by a wheel or bumper time to move to safety. If the space is tight, get someone to stand outside the vehicle and direct you.

## VEHICLE & ENGINE SAFETY (cont.)



### SAFETY PROCEDURES

- Engine radiators contain engine coolant, which can reach 100°C and be under pressure. Do not remove the radiator cap on a warmed up engine as this can burn your hands or face. Feel the radiator hose with your hand, if it is cool to the touch, and can be squeezed, you can remove it. Exhaust system parts can also cause burns - keep body parts away from exhaust system components.
- When a fuel system is being repaired, fuel vapors may be present. To prevent a fire, disconnect the negative battery terminal so the electrical system won't inadvertently lead to a vehicle fire.
- Use extreme caution when working on a running engine. Keep tools, hair and other body parts away from rotating belts, pulleys and fans.
- If you are working on the brake system or on the clutch of a vehicle, wear a particle mask and do not create airborne dust by blowing on these parts with an air nozzle. Wet-washing is also recommended to prevent dust from becoming airborne. These parts may contain asbestos, a cancer-causing substance.
- When working on a small engine, such as a lawn mower, make sure it won't start if the crankshaft is inadvertently moved. Disconnect all spark plug leads to prevent the engine from starting.
- After repair and prior to start-up, ensure engine is clear and safe to start.
  - Remove any tools and parts from the engine compartment.
  - Ensure no fuel leaks or fuel vapors are present.
  - Verify no one has their hands or any other body part in the path of the engine's rotating parts

## Safety Around Vehicles Test

Student Name: \_\_\_\_\_ Date: \_\_\_\_\_

	TRUE/FALSE	
1. The exhaust retraction system is not needed provided a shop door is open to allow exhaust gasses to dissipate.	<b>T</b>	<b>F</b>
2. The radiator hose is hot to the touch. The radiator cap should not be removed.	<b>T</b>	<b>F</b>
3. It is not essential to tie back long hair when working on an engine provided the engine will not be started.	<b>T</b>	<b>F</b>
4. Exhaust system parts can be extremely hot and can cause serious burns.	<b>T</b>	<b>F</b>
5. The most effective way to clean brake dust from a brake assembly during service is to use an air nozzle and compressed air.	<b>T</b>	<b>F</b>
6. No special precautions are necessary when removing a fuel tank from a vehicle.	<b>T</b>	<b>F</b>
7. You can drive a vehicle in or out of the shop without a license as long as you do not leave the school property.	<b>T</b>	<b>F</b>
I have discussed shop safety with the instructor and understand that I need to be careful when working around power tools so nobody gets injured.  <b>Signed:</b> _____	<b>SCORE:</b> /	



## AIR TOOLS

An air tool or pneumatic tool is a type of power tool, driven by compressed air, supplied by an air compressor.



Pneumatic air hose with quick-connect couplers



## SAFETY PROCEDURES

- Wear approved eye protection.
- Dress properly. Do not wear loose clothing or jewelry. Loose clothing can get caught in moving parts.
- Keep work area clean and well lit. Cluttered or dark areas invite accidents.
- Compressed air can be dangerous.
- Use only recommended fittings and air lines. Air hoses must have a minimum working pressure rating of 150 psi.
- Be sure that the tools, hoses and their couplings are in good condition. A weak/defective air hose, which becomes severed, will whip around violently until the air is shut off. Immediately replace any hoses with cracks or bulges.
- With many impact air tools hearing protection may be required.
- Do not play with compressed air and do not use compressed air to blow dust off your clothes.
- Flying particles and debris may be discharged when operating some air tools. Wear eye protection.
- Never set a tool down while it is still in motion. Setting a tool down while it is still in motion may cause it to move uncontrollably and may cause injury or death to you or people around you.
- With grinding and cutting attachments, never exceed their rated maximum speeds.
- After repair and prior to start-up, ensure engine is clear and safe to start.
- Remove any tools and parts from the engine compartment.
- Ensure no fuel leaks or fuel vapors are present.
- Verify that no one has their hands or other body parts in the path of the engine's rotating parts.

## Air Tool Safety Test

Student Name: \_\_\_\_\_ Date: \_\_\_\_\_

	TRUE/FALSE	
1. Compressed air is an appropriate method to clean dust off your clothing.	T	F
2. Eye protection is required as chips or particles may be ejected from air tool.	T	F
3. Air hoses with minor bulges or cracking can be used provided the hose is not leaking.	T	F
4. Air tools should stop rotating before being placed down.	T	F
5. The air supply valve to an air hose should be in the off position when not in use or when changing power tools.	T	F
6. Air tools should only be carried by the hose attached to it.	T	F
I have discussed shop safety with the instructor and understand that I need to be careful when working around power tools so nobody gets injured.  Signed: _____	<b>SCORE:</b>	/

**SAFE BATTERY HANDLING****SAFETY PROCEDURES**

- Wear approved eye protection.
- Dress properly. Do not wear loose clothing or jewelry. Loose clothing can get caught in moving parts.
- Keep work area clean and well lit. Cluttered or dark areas invite accidents.
- Lead/acid batteries used in vehicles contains a mixture of water and sulfuric acid that can ruin your clothing and burn your skin. Protect yourself by wearing eye protection, a face shield if there is risk of injury to the face, appropriate gloves, shop coat and an apron. Clean the battery before you handle it. You can neutralize the acid with a solution of baking soda and water. If you get acid on yourself, flush it off with lots of water.
- The chemical reaction in a lead/acid battery produces hydrogen gas—a very explosive substance. Keep sparks or flames away from batteries, especially when they are being charged.
- When connecting a battery to a charger, attach the leads to the battery, then turn the charger on. To disconnect, turn the charger off; unplug the charger from the electrical outlet, then unclip the leads from the battery. Wear a face shield when charging a battery.
- When a battery is charging, you should monitor the temperature by putting your hand on the side of it every half-hour or so. If the battery gets hot, it is most likely defective and should be replaced; do not continue to charge it. Don't leave a battery charging if you are unable to monitor it.
- When removing a battery from of a vehicle, disconnect the ground lead first. This reduces the chances of accidentally causing a short circuit as you work around the battery.
- Never attempt to charge or jump-start a maintenance free battery if the charge indicator shows that the battery's electrolyte is low – the battery could explode. It is time to replace it.
- Never attempt to charge or jump-start a frozen battery. The battery could explode.

## Automotive Battery Safety Test

Student Name: \_\_\_\_\_ Date: \_\_\_\_\_

	TRUE/FALSE	
1. Skin can burn and clothing can be ruined by the water and sulphuric acid mixture in a battery.	<b>T</b>	<b>F</b>
2. Hydrogen gas is highly explosive.	<b>T</b>	<b>F</b>
3. Sparks or open flames around the top of a battery are generally not a concern because the battery is sealed and there aren't any flammable materials in that area.	<b>T</b>	<b>F</b>
4. When removing a battery from a vehicle, it is best to disconnect the negative terminal first.	<b>T</b>	<b>F</b>
5. When using a battery charger, plug the charger in, turn it on then connect it to the battery.	<b>T</b>	<b>F</b>
6. When a battery is being charged, it is normal for it to get hot.	<b>T</b>	<b>F</b>
7. Eye protection is recommended, but not essential when working with batteries.	<b>T</b>	<b>F</b>
<p>I have discussed shop safety with the instructor and understand that I need to be careful when working around power tools so nobody gets injured.</p> <p><b>Signed:</b> _____</p>	<b>SCORE:</b> /	

## ENGINE CRANE

An engine crane or engine hoist, is used to remove and install engines in vehicles.

### Important parts:

- Chain hook assembly
- Leg extensions
- Boom
- Support strut
- Hydraulic unit
- Handle

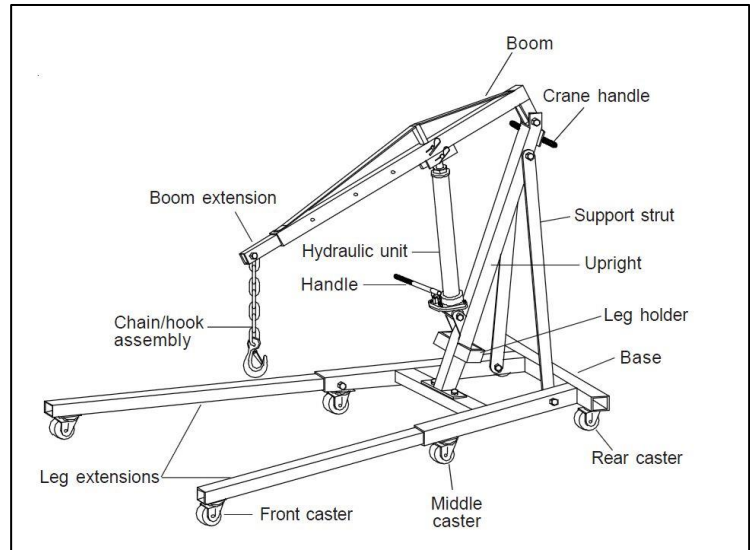

## SAFETY PROCEDURES

- Carefully inspect engine crane for any faults - check that all bolts/pivots are securely in place. Inspect hydraulic cylinder for leaks. Report any deficiencies to your teacher.
- Wear approved eye protection.
- Dress properly. Do not wear loose clothing or jewelry. Loose clothing can get caught in moving parts.
- Keep work area clean and well lit. Cluttered or dark areas invite accidents.
- Before you begin any work on a vehicle, make sure it cannot roll. Put the transmission in park for an automatic transmission, and neutral for a standard transmission. Set the parking brake, remove the keys from ignition and then chock the wheels.
- Connect high strength chain to engine using high strength fasteners. Have your teacher verify the bolts threads are sufficiently long and of the correct diameter to prevent injury or damage to vehicle.
- Never attempt to lift a load heavier than the rated capacity of the engine crane because overloaded cranes can fail.
- If boom length is adjustable, make sure that weight limits are not exceeded for the various positions.
- Stay out from underneath the crane when an engine is being lifted or suspended.
- Lift engine until it is high enough to roll the crane away from vehicle. Move slowly and cautiously. When moving an engine on a hoist, you must be careful that it does not tip over. Always lower the boom on the hoist as much as possible to prevent tipping of the hoist. Keep the center of gravity as low as possible.

## Engine Hoist Safety Test

Student Name: \_\_\_\_\_ Date: \_\_\_\_\_

	TRUE/FALSE	
1. An engine hoist with a loose or wobbly wheel can be used provided the hoist is not used to move the engine.	<b>T</b>	<b>F</b>
2. Only high strength chains should be used to secure an engine to the engine hoist.	<b>T</b>	<b>F</b>
3. Engines can be repaired when suspended from an engine hoist.	<b>T</b>	<b>F</b>
4. Before lowering an engine to the floor, go underneath the engine and check to make sure it is securely attached to the hoist.	<b>T</b>	<b>F</b>
5. The best way to move an engine around the shop while it is suspended by the hoist is to raise the hoist to its maximum lifting height.	<b>T</b>	<b>F</b>
6. When lowering the engine, it is best to do it slowly and gradually.	<b>T</b>	<b>F</b>
7. As the boom is moved inward, it's capacity is reduced.	<b>T</b>	<b>F</b>
I have discussed shop safety with the instructor and understand that I need to be careful when working around power tools so nobody gets injured.  <b>Signed:</b> _____	<b>SCORE:</b> /	

## ENGINE STAND

An engine stand is a tool used to repair large gasoline or diesel engines. It uses a heavy cantilevered support structure to hold the engine in midair so that you can access any exposed surface of the engine.

### Important Parts:

- Mounting arm
- Operating handle
- Rotation lock bolt
- Head plate

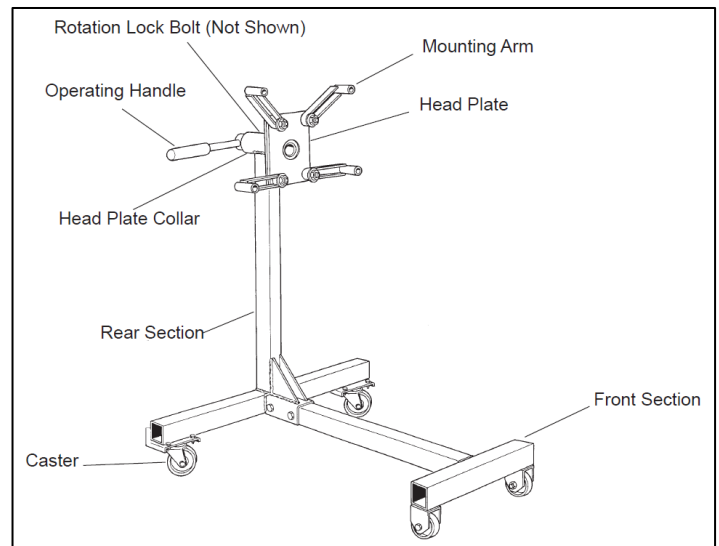

## SAFETY PROCEDURES

- Wear approved eye protection. Dress properly. Do not wear loose clothing or jewelry. Loose clothing can get caught in moving parts.
- Keep work area clean and well lit. Cluttered or dark areas invite accidents.
- Inspect engine stand before each use. Do not use if there are bent, broken or cracked components. Ensure that casters/wheels and adapter plate rotate freely. Check for any loose assemblies and tighten as needed.
- Do not exceed rated capacity. Use only on a hard, level surface.
- Lock head plate rotating mechanism before applying load.
- Use hardened, appropriately sized bolts to secure engine to stand.
- Ensure engine is centered and secured to the head plate. Off-center loading may cause the engine to rotate unexpectedly and cause the loaded stand to tip over.
- When an engine is mounted, take the weight of the engine on the handle before removing the locking pin.
- Unlock and apply rotating mechanism slowly and carefully.
- To move a loaded stand, steady the load and push from behind the main post of the stand so that the castor wheels are ahead of the load.
- Do not pull the engine stand backwards, or push from the side, as this may cause the stand to tip.
- **DANGER!** Do not work under an engine mounted on the stand.
- Do not support the engine using only the crane. Immediately transfer the engine to an engine stand.

## Engine Hoist Safety Test

Student Name: \_\_\_\_\_ Date: \_\_\_\_\_

	TRUE/FALSE	
1. An engine hoist with a loose or wobbly wheel can be used provided the hoist is not used to move the engine.	<b>T</b>	<b>F</b>
2. Only high strength chains should be used to secure an engine to the engine hoist.	<b>T</b>	<b>F</b>
3. Engines can be repaired when suspended from an engine hoist.	<b>T</b>	<b>F</b>
4. Before lowering an engine to the floor, go underneath the engine and check to make sure it is securely attached to the hoist.	<b>T</b>	<b>F</b>
5. The best way to move an engine around the shop while it is suspended by the hoist is to raise the hoist to its maximum lifting height.	<b>T</b>	<b>F</b>
6. When lowering the engine, it is best to do it slowly and gradually.	<b>T</b>	<b>F</b>
7. As the boom is moved inward, it's capacity is reduced.	<b>T</b>	<b>F</b>
I have discussed shop safety with the instructor and understand that I need to be careful when working around power tools so nobody gets injured.  <b>Signed:</b> _____	<b>SCORE:</b> /	



## BRAKE LATHE

A brake lathe is used to machine a fresh surface onto brake discs and drums. This machining process removes any imperfections from the braking surface of the disc or drum.

### Important Parts:

- Power cord
- Twin cutter
- Spindle feed
- Cross feed
- Spindle feed hand wheel
- Cross feed hand wheel

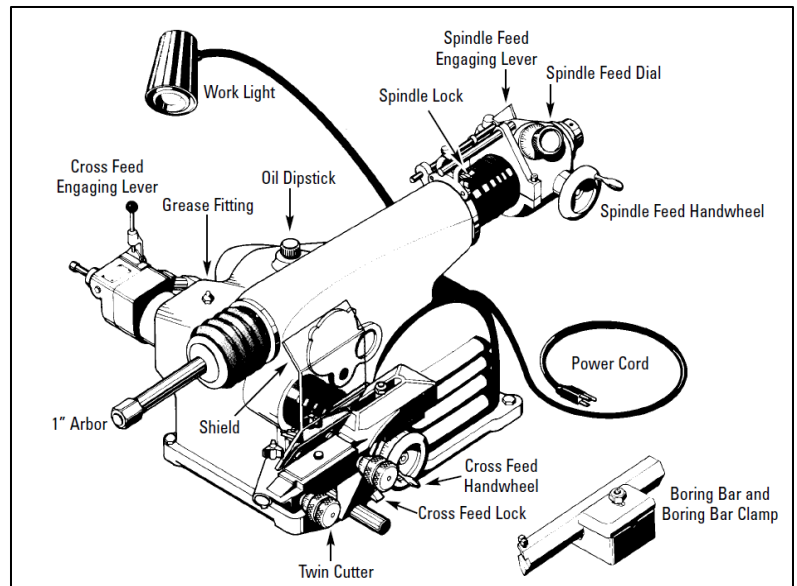

## SAFETY PROCEDURES

- Wear approved eye protection.
- Dress properly. Do not wear loose clothing or jewelry. Loose clothing can get caught in moving parts.
- Keep work area clean and well lit. Cluttered or dark areas invite accidents.
- Do not remove any safety equipment or belt guards.
- Make sure drums or rotors are properly mounted and that all parts are secure before starting the lathe.
- Keep fingers or any other body part away from the cutters while the machine is in operation.
- Do not touch the brake disc or drum while it is spinning or attempt to stop it.
- If the lathe is making unusual sounds such as squealing or groaning, turn the machine off and call your teacher over as something may be incorrectly mounted or loose.

## Brake Lathe Safety Test

Student Name: \_\_\_\_\_ Date: \_\_\_\_\_

	TRUE/FALSE	
1. When machining brake discs or drums, it is normal for the machine to make high-pitched squealing or groaning sounds.	<b>T</b>	<b>F</b>
2. Machining particles are best cleared away with your fingers while the machine is spinning to ensure the debris is completely removed.	<b>T</b>	<b>F</b>
3. If the safety shield impairs your vision during machining, it is best to swing it out of the way.	<b>T</b>	<b>F</b>
4. The brake lathe should not be left running and unattended.	<b>T</b>	<b>F</b>
5. You should touch the surface of the drum or rotor while the lathe is turning to check for surface smoothness.	<b>T</b>	<b>F</b>
6. After turning off the brake lathe, you can safely stop the rotor or drum from spinning only if you are wearing gloves.	<b>T</b>	<b>F</b>
7. Safety glasses are not required when using a brake lathe as they are equipped with a built-in shield.	<b>T</b>	<b>F</b>
<p>I have discussed shop safety with the instructor and understand that I need to be careful when working around power tools so nobody gets injured.</p> <p><b>Signed:</b> _____</p>	<b>SCORE:</b> /	

## JACK & JACK STAND SAFETY

A service jack is used to lift a vehicle off the floor so it can be serviced or repaired. Once raised, a jack stand is used to support the vehicle.

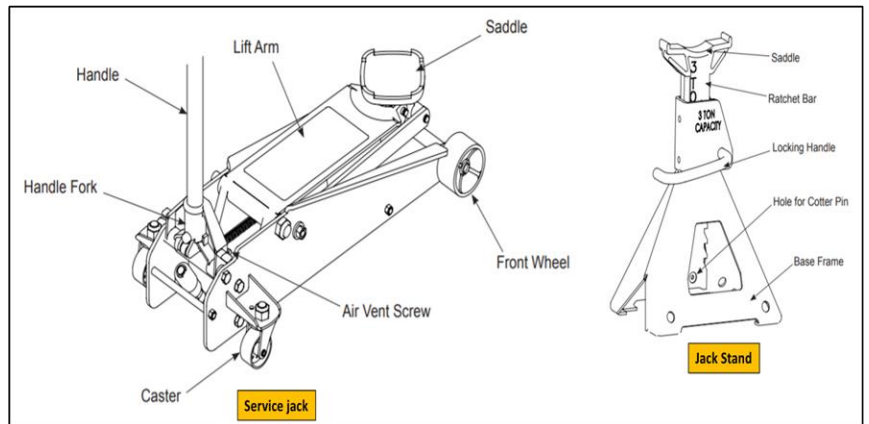

### SAFETY PROCEDURES

- Wear approved eye protection.
- Dress properly. Do not wear loose clothing or jewelry. Loose clothing can get caught in moving parts.
- Inspect the jack before each use. Do not use jack if damaged, leaking hydraulic fluid, or unstable due to loose or missing hardware or parts.
- Keep work area clean and well lit. Cluttered or dark areas invite accidents.
- Only use the jack on level, solid ground such as concrete.
- Engage the parking brake and choke each un-lifted wheel in both directions to prevent inadvertent vehicle movement.
- Never work under the vehicle until appropriately supported with jack stands.
- Do not exceed rated capacity of the jack or jack stands.
- Before using the jack to lift a vehicle, refer to the vehicle service manual to determine recommended lifting points - consult with your teacher if you are unsure about where to place the jack.
- Do not use blocks or other extenders between the saddle and the load being lifted.
- Check that the lifting point is stable and centered on the jack saddle.
- Do not use the jack to move/roll the vehicle - it is not designed for this purpose.
- Jack stands are not to be used to simultaneously support both ends, or one whole side of a vehicle.
- Use jack stands under the vehicle before proceeding with any task.
- Ensure no people, tools or parts are beneath the vehicle before lowering it.
- Lift and support the front or the rear of the vehicle, but never both at the same time.

## Jack & Jack Stand Safety Test

Student Name: \_\_\_\_\_ Date: \_\_\_\_\_

	TRUE/FALSE	
1. A floor jack leaking hydraulic fluid can be used provided it is capable of lifting the vehicle.	<b>T</b>	<b>F</b>
2. Only use the jack on sand, dirt or gravel.	<b>T</b>	<b>F</b>
3. Chocking the wheels is not required if the parking brake has been securely engaged.	<b>T</b>	<b>F</b>
4. To identify the correct jacking locations under a vehicle, refer to the manufacturer's recommended jack points in the service information.	<b>T</b>	<b>F</b>
5. If a jack can't raise a vehicle high enough, lower the jack and place wooden spacers on the jack's saddle, then raise the vehicle again.	<b>T</b>	<b>F</b>
6. In addition to lifting a vehicle, jacks also allow you to roll a vehicle around the shop to an alternate location.	<b>T</b>	<b>F</b>
7. Jack stands are not required if you are removing a wheel and will not be going under the vehicle.	<b>T</b>	<b>F</b>
8. Jack stands can be used individually, to support one corner of a vehicle, in pairs to support the front or rear, or with two pairs to support both the front and rear of the vehicle.	<b>T</b>	<b>F</b>
9. A vehicle weighing 1600kg can be supported by a pair of jack stands rated at 2 tons or 1800kg.	<b>T</b>	<b>F</b>
I have discussed shop safety with the instructor and understand that I need to be careful when working around power tools so nobody gets injured.  <b>Signed:</b> _____	<b>SCORE:</b> /	

## 2 POST HOIST

A two post lift is a stationary machine that is used to lift up and service vehicles when the vehicle needs to be off the ground or suspended for certain operations.

### Important parts:

- Upright columns
- Lock release
- Electric hydraulic
- Power unit
- Vehicle lift arms



## SAFETY PROCEDURES

- When moving under the lift make sure your instructor is there to guide you, the vehicle must be centered between upright columns under the overhead beam for balance.
- While moving under the lift make sure there are no objects in view (honk horn & check blind spots).
- Once in position under the lift, place vehicle in park (AUTOMATIC) or neutral (MANUAL) with parking brake on.
- Leave keys in ignition (in the OFF position) and leave driver side window down to access vehicle.
- Before lifting the vehicle weight off of the wheels, position the lift arms at the lift points. Get instructor to check the lift points and prepare to raise the vehicle.
- Announce that the lift is going up.
- Use the raise button on the electric hydraulic power unit to lift vehicle.
- When raising/lowering the lift no one should be within two feet of the vehicle.
- Raise lift to desired height, while ensuring that the vehicle roof doesn't contact the overhead beam, and lower onto safety locks.
- Before lowering ensure that all tools, hoses and people are out from under the lift.
- Raise lift off of locks and activate the single point release lock before pushing the lowering lever and lowering the lift to the ground.
- Remove vehicle lift arms from underneath of vehicle before moving.
- When you are finished using the jack, lower it fully and store it with the handle in the upright position.

## 4 POST HOIST

A four post lift is a stationary machine that is used to lift up and service vehicles when the vehicle needs to be off the ground or suspended for certain operations.

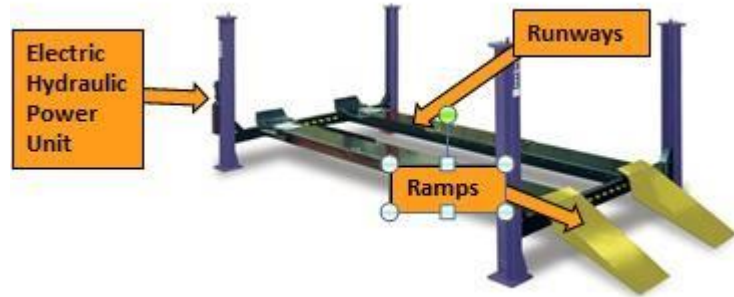

### Important Parts:

- Ramps
- Runways
- Electric Hydraulic Power Unit

## SAFETY PROCEDURES

- When moving on/off the lift make sure your instructor is there to guide you.
- While moving on/off the lift make sure there are no objects in view (honk horn & check blind spots).
- Don't stop while driving onto lift, movement should be one continuous motion.
- Once in position on the lift, place vehicle in park (AUTOMATIC) or neutral (MANUAL) with parking brake on.
- Leave keys in ignition (in the OFF position) and leave driver side window down to access vehicle.
- Chock one wheel on both sides of the wheel.
- Announce that the lift is going up.
- When raising/lowering the lift no one should be within two feet of the vehicle.
- Raise lift to desired height and lower onto safety locks.
- Position the rolling jacks at the lift points. Position the lift pads at the lift points. Get instructor to check the lift pads and prepare to raise the vehicle.
- Raise vehicle off of lift surface and ensure that safety lock on rolling jack engages, make sure that you raise the wheels without chocks first to ensure no vehicle movement.
- When lowering ensure that all tools, hoses and people are out from under the lift.
- Raise lift off of locks and activate the single point release lock before pushing the lowering lever and lowering the lift to the ground.
- Before driving vehicle off of the lift make sure that you un-chock your wheels.

## 2/4 Post Hoist Safety Test

Student Name: \_\_\_\_\_ Date: \_\_\_\_\_

	TRUE/FALSE	
1. Don't stop while driving onto lift, movement should be one continuous motion.	<b>T</b>	<b>F</b>
2. Chock one wheel on both sides of the wheel.	<b>T</b>	<b>F</b>
3. It does not matter if your instructor does not check your placement of lift points.	<b>T</b>	<b>F</b>
4. You should announce that the lift is going up.	<b>T</b>	<b>F</b>
5. No one should be closer than 3 feet when raising or lowering the vehicle on the hoist.	<b>T</b>	<b>F</b>
6. You should leave the keys in the ignition and the driver's side window down to ensure access.	<b>T</b>	<b>F</b>
7. When lowering your vehicle you should ensure that no hoses or tools are left out.	<b>T</b>	<b>F</b>
I have discussed shop safety with the instructor and understand that I need to be careful when working around power tools so nobody gets injured.  <b>Signed:</b> _____	<b>SCORE:</b> /	

## HYDRAULIC PRESS

A hydraulic press is a device using a hydraulic cylinder to generate a compressive force.

### Important Parts:

- V Blocks
- Work head nose
- Table / bed plate

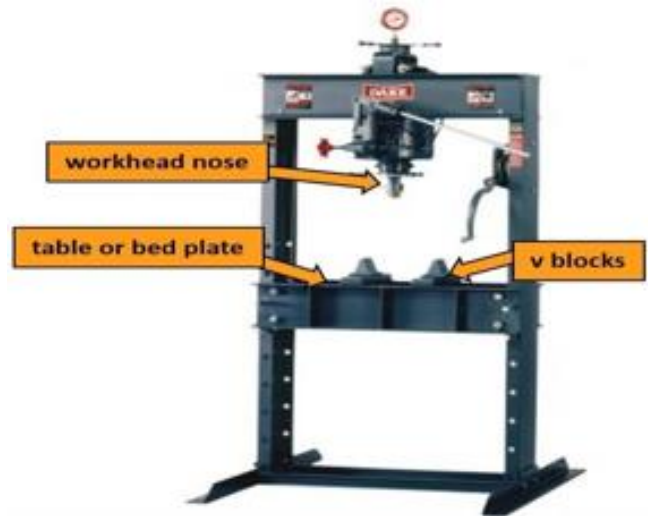

## SAFETY PROCEDURES

- **Potential Hazards:** The hydraulic press can lead to serious injury as a result of:
  - your hand can getting caught between the ram and the work piece leading to a crushing injury
  - the workpiece can be ejected while under pressure causing a striking injury
  - the workpiece can shatter causing fragments to lacerate or puncture your body
- Wear approved face shield.
- Dress properly. Do not wear loose clothing or jewelry. They can get caught in moving parts.
- Keep work area clean and well lit. Cluttered or dark areas invite accidents.
- Check machine for damaged parts prior to operation. Alert your instructor if parts are damaged.
- Do not use machine if any part(s) are broken or damaged.
- The press is used to bend, press and straighten parts only. Don't use it for any other purpose.
- Ensure work piece is placed squarely on the plate.
- Clamp work piece (if appropriate).
- Make sure other people are clear of the work area.



## SOLVENT TANK

Solvent degreasing is a process used to prepare a part for further operations such as electroplating or painting. Typically it uses petroleum, chlorine, or alcohol based solvents to dissolve the machining fluids and other contaminants that might be on the part.

### Important Parts:

- Solvent tank
- Fusible link



## SAFETY PROCEDURES

- Solvent tanks use petroleum-based chemicals to clean oily or greasy parts. These solvents are flammable and toxic.
- Wear approved eye protection.
- Use rubber or nitrile disposable gloves.
- Solvent can stain your clothing. Wear a chemical-resistant apron if needed.
- Keep sparks and open flames away from the solvent tank.
- Watch for other students who may be generating sparks with grinding or cutting tools.
- Solvent tanks must be equipped with a fused, self-closing lid that will close the lid if a fire were to start.
- Do not prop the lid open. This will disable the self-closing feature.

## WHEEL BALANCER

When tires are fitted to wheels at the point of sale, they are measured again on a balancing machine, and correction weights are applied to counteract the combined effect of the tire and wheel unbalance. After sale, tires may be rebalanced if driver perceives excessive vibration.

### Important Parts:

- Hood guard
- Mounting cones
- Arbor shaft



## SAFETY PROCEDURES

- Wear approved eye protection.
- Dress properly. Do not wear loose clothing or jewelry. They can get caught in moving parts.
- Keep work area clean and well lit. Cluttered or dark areas invite accidents.
- Check machine for damaged parts prior to operation. Alert your instructor if parts are damaged.
- Do not use machine if any part(s) are broken or damaged.
- Do not disable hood safety interlock system (if equipped), or in any way shortcut safety controls and operations.
- Be sure that wheel is mounted properly and the hub nut engages the arbor at least four turns, and the hub nut is firmly tightened before spinning the wheel.
- Keep hair, loose clothing, and body parts away from rotating arbor.
- Know where the emergency stop button is on the balancer and how to use it.
- Do not attempt to balance wheels that are larger than the machine was designed for.
- Select the cone that best fits the center hole in the wheel.
- Do not raise the hood (if equipped) until the tire has come to a complete stop.

## TIRE MACHINE

A tire changer is a machine used to help tire technicians dismount and mount tires with automobile wheels.

### Important Parts:

- Turntable
- Pedals
- Bead breaker
- Mount/demount head

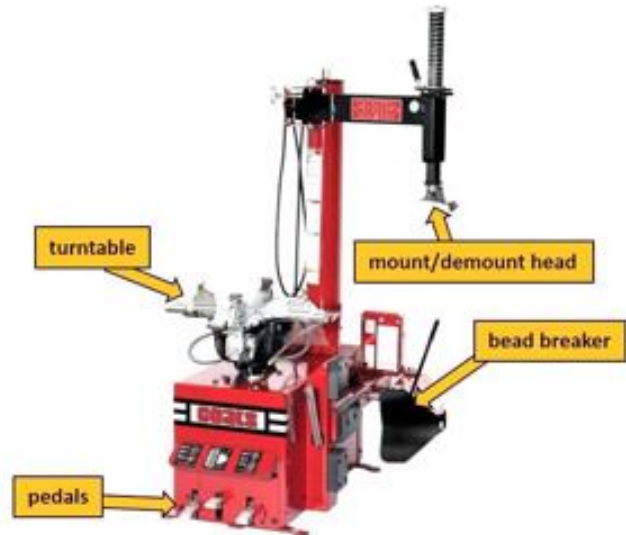

## SAFETY PROCEDURES

- Wear approved eye protection.
- Dress properly. Do not wear loose clothing or jewelry. They can get caught in moving parts.
- Keep work area clean and well lit. Cluttered or dark areas invite accidents.
- Check machine for damaged parts prior to operation. Alert your instructor if parts are damaged.
- Do not use machine if any part(s) are broken or damaged.
- Inspect tires and rims for defects (cracks, bends, bulges, etc.) prior to mounting.
- Do not attempt to mount defective tires.
- Never mount a tire on a defective wheel.
- Always make sure tire size matches rim size prior to mounting (eg. 15" tire on a 16" wheel).
- Mismatched tire/rim combinations can explode.
- Keep hands clear of all pinch points.
- Do not lean over turntable while inflating tire.
- Keep hands and body clear at all times and as far back as possible during inflation. An exploding tire can cause serious injury or death. Remain clear at all times.
- When seating beads, never exceed 40psi. If tire bead does not seat at 40psi, immediately relieve pressure and check for damaged bead or other cause.

## Wheel Balancer / Tire Machine Safety Test

Student Name: \_\_\_\_\_ Date: \_\_\_\_\_

	TRUE/FALSE	
1. Wear approved eye protection.	<b>T</b>	<b>F</b>
2. Keep work area clean and well lit. Cluttered or dark areas invite accidents.	<b>T</b>	<b>F</b>
3. Know where the emergency stop button is on the balancer and how to use it.	<b>T</b>	<b>F</b>
4. You can raise the hood (if equipped) even if the tire has not come to a complete stop.	<b>T</b>	<b>F</b>
5. Inspect tires and rims for defects (cracks, bends, bulges, etc.) after mounting.	<b>T</b>	<b>F</b>
6. Keep hands and body clear at all times and as far back as possible during inflation. An exploding tire can cause serious injury or death. Remain clear at all times.	<b>T</b>	<b>F</b>
7. When seating beads, never exceed 40psi. If tire bead does not seat at 40psi, immediately relieve pressure and check for damaged bead or other cause.	<b>T</b>	<b>F</b>
I have discussed shop safety with the instructor and understand that I need to be careful when working around power tools so nobody gets injured.  <b>Signed:</b> _____	<b>SCORE:</b> /	

# MAKER:

## Makerspace Safety Rules

1. Operate machines/equipment **ONLY** with the instructor's permission and after you have received proper instruction and a go-ahead to use the materials with that machine.
2. Always use appropriate Personal Protective Equipment (PPE), such as safety glasses when using power tools. Dress properly for the task, i.e. no loose clothing around machines such as a lathe or drill press.
3. All accidents must be reported to the instructor immediately.
4. Don't use tools or equipment that are in any way defective/damaged. Tell the instructor immediately if the equipment doesn't look proper.
5. Use safety glasses and gloves when using acids.
6. The floor must be kept clean. Don't leave anything lying around that could be tripped on or slipped on.
7. Use ALL recommended guards and safety devices on the machinery/equipment as shown by your instructor.
8. Machines that produce hot products, like 3D printers, should be handled carefully with correct PPE worn, such as gloves.
9. If equipment like 3D printers, Laser Engraves and Soldering stations have exhaust extraction, ensure it is on before starting the machine.
10. Ensure toolpath will not damage machine before starting a cut.
11. Do not look directly at the light where the laser is cutting your material.

## Makerspace Safety Test

Student Name: \_\_\_\_\_ Date: \_\_\_\_\_

	TRUE/FALSE	
1. Ask instructors permission before using any equipment/machines	T	F
2. 3D printers have no hazards	T	F
3. The laser engraver must have exhaust extraction running whenever the machine is being operated	T	F
4. Getting someone's attention is more important than their safety when operating a machine	T	F
5. Long hair can be worn when working on machinery such as a drill press	T	F
6. Soldering stations give off toxic fumes, avoid breathing the fumes	T	F
7. Laser light is not hazardous to your eyes	T	F
8. Gloves are recommended if working with hot filament on a 3D printer	T	F
9. The purpose of checking a tool path before using a machine like a laser cutter or a drill, is to ensure no damage occurs to the machine	T	F
10. Acid used in circuit board production is too mild to harm you	T	F
I have discussed shop safety with the instructor and understand that I need to be careful when working around power tools so nobody gets injured.  <b>Signed:</b> _____	<b>SCORE:</b> /	

## SOLDERING PENCIL /IRON

A hand-operated tool with a tip that can reach temperatures of 425°C (800°F). Used to melt solder to join metals together without melting the base material.

### Important parts:

- Tip
- Body
- Cord / Plug in



## SAFETY PROCEDURES

- Wear approved eye protection. Ensure long hair is tied back, all jewelry is removed, and you are wearing closed toed shoes. \*It is recommended that long pants be worn as well\*
- When you plug in the soldering pencil/iron make sure the cord does not touch the tip.
- The tip is HOT and should not be touched.
- Always place the soldering pencil in the holder – NOT ON THE DESK/TABLE
- Use proper ventilation or fume extraction. Keep face 1- 2 feet away from your work. Never breathe in the fumes.
- Melted solder can burn through clothes and your skin. Never solder upside down
- \*\*\* Hold the items to be soldered upside down.\*\*\*
- Unplug the unit by grasping the plug, NOT the cord.
- Put your soldering pencil/iron away in the appropriate location, ensuring the tip does not touch the cord. Soldering pencils stay hot for a long time after they are unplugged.



## ETCHNANT TANK

Etching tanks are used to remove unwanted copper from printed circuit boards. The solution used is either ferric chloride or ammonium persulfate.

### Important Parts:

- Clip
- Heater
- Air pump
- Tank

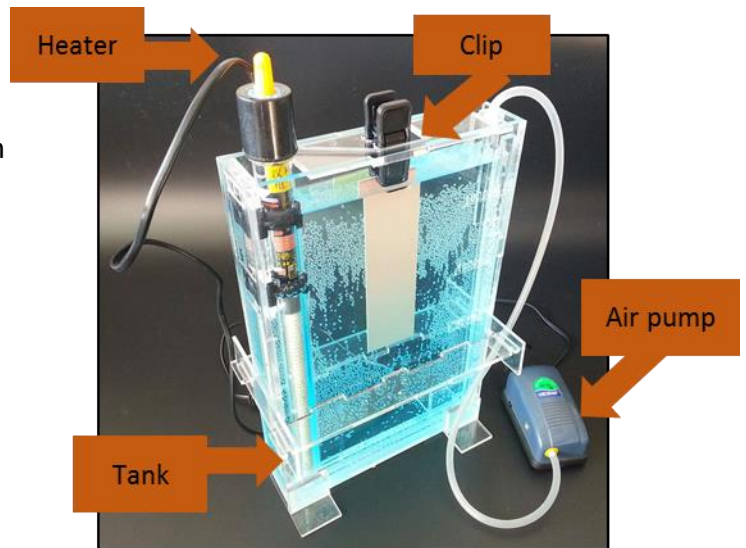

## SAFETY PROCEDURES

- Wear approved eye protection and a face shield.
- Dress properly. Cover your clothes with either coveralls or a lab coat to protect your clothing.
- Keep work area clean and well lit. Cluttered or dark areas invite accidents.
- Wear gloves. – Must be Acid resistant.
- Do not heat Ferric Chloride above 55°C.
- Ensure there is adequate ventilation in the area of the etchant tank.

## LASER ENGRAVER

Laser engraving is the process by which a computer controlled laser beam changes the surface of a material. The high heat of the beam causes the material to burn or melt.

### Important Parts:

- Lid
- Control system
- Worktable
- Laser

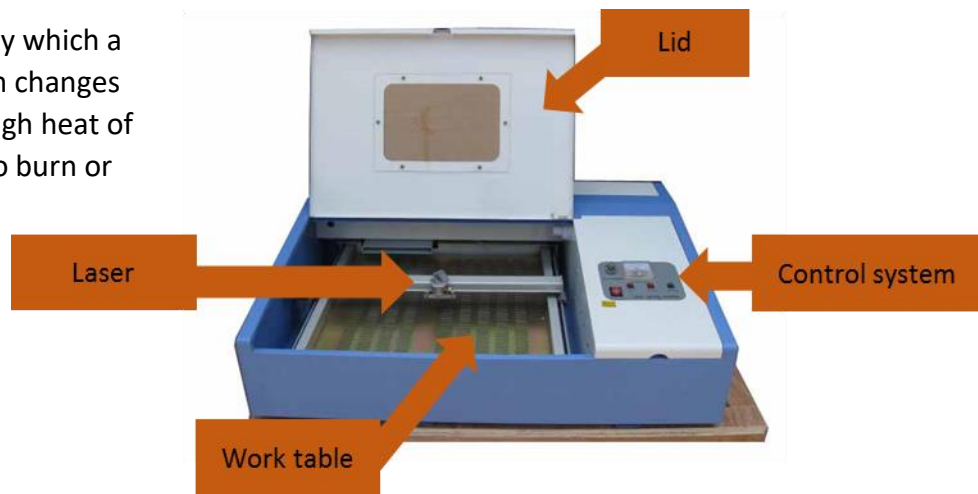

## SAFETY PROCEDURES

- Ensure that you have adequate ventilation and that it is turned on before use.
- Verify that your toolpath is going the correct direction, and that the origin point is in the correct location. Ask your teacher to inspect the program before you export it.
- Clear off any material on the cutting bed before placing your material in the machine.
- Do not cut any plastics or foam unless your teacher has told you that it is acrylic. Many plastics contain vinyl which becomes a poisonous gas when burned.
- Ensure that the machine power is turned on, the blower motor is turned on and the coolant pump is running before running your program.
- Close the lid of the machine prior to operation, and keep it closed until the machine has stopped cutting.
- Do not look directly at the light where the laser is cutting your material as this is very bright and may damage your eyes.

## 3D PRINTER

3D printing is a process by which material is joined or solidified under computer control to create a 3D object.

### Important parts:

- Filament
- Print head
- Worktable
- Control system

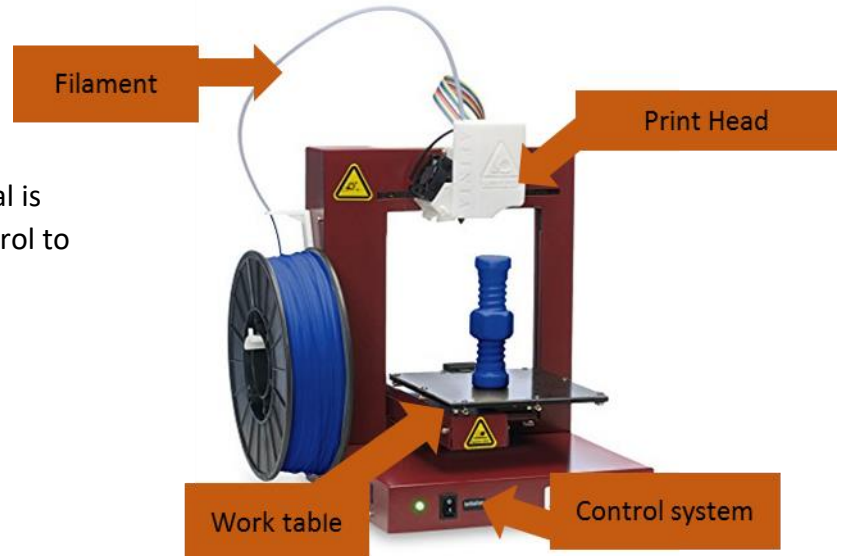

## SAFETY PROCEDURES

- Ensure that you have adequate ventilation and that it is turned on before use.
- Verify that your toolpath is going the correct direction, and that the origin point is in the correct location. Ask your teacher to inspect the program before you export it.
- Clear off any material on the cutting bed before starting.
- Keep all extremities away from the machine while it is printing, if equipped with a door, ensure that it is closed for the entire print.
- Use leather gloves to protect your hands and safety glasses to protect your eyes when removing your work from the worktable.
- Keep in mind that the print head and the worktable are both heated and can burn you: Do not touch!

# Appendix I

## Case Studies

A number of school accidents have resulted in litigation in the BC court system. The following case studies have been provided to give you some insight into how the courts view the issue of liability, and to reinforce the need for precautions to protect your students from injury and yourself from liability.

Case No. 1	<b>Loss of Arm</b>
Location	Metal Shop
Incident	A grade 10 student lost his lower arm while assisting the operator of a metal lathe.
Circumstances	<p>Student A was operating a metal lathe in an after-school Stagecraft class. He was turning the end of a long piece of round metal stock that protruded through the head stock. Student A asked Student B to put on a pair of leather gloves and cradle the end of the stock as it turned to minimize wobbling from the protruding end. Student B did as he was asked.</p> <p>The stock grabbed Student B's gloves and an unbuttoned sleeve of his jean jacket. Even though the machine was shut off almost immediately, Student B's arm was twisted from its socket at the shoulder and broken in two places. It was held together only by sinews.</p> <p>One of the two shop teachers present at the time was qualified in Industrial First Aid. He laid the student on a bench and used pressure points to prevent Student B from bleeding to death. An ambulance arrived shortly thereafter.</p> <p>During extensive surgery the arm was reattached but efforts to restore circulation to the lower arm were not successful. The arm had to be amputated at the elbow. Student B was eventually fitted with a prosthesis.</p>
Liability	After a thorough investigation, it was found that there was no negligence on the part of the teachers. Although both were present in the shop, the procedure that resulted in the accident happened without their prior knowledge or permission. It was found that adequate instruction and supervision was in place.

Case No. 2	<b>Hand Injury</b>
Location	Wood Shop
Incident	A student in a grade 9 shop class severely cut three fingers on her left hand while using an electrically operated wood planer.
Circumstances	<p>The student testified that the injury occurred when she experienced a problem while operating the planer—it was clogging up with chips and sawdust as she was using it. During her first attempt to solve the problem, she shut off the planer, lifted the rubber flap with her dominant left hand, and scraped the chips and sawdust into the dust collector at the back of the table with her right hand. However, the problem continued.</p> <p>During her second attempt to solve the problem, she lifted the safety flap and scraped the chips and sawdust towards the dust collector <b><u>while the machine was running</u></b>. Her left hand came into direct contact with the planer’s cutting head. Three fingers were severely cut.</p> <p>Before the accident, the student had received safety instruction in grades 8 and 9 on the use of power tools and machinery. She was also instructed to never make any adjustments of any kind while a machine was running, to keep her hands away from moving parts, and to ask for help when she had a problem. The teacher, who had over 10 years of experience as a shop teacher, emphasized the importance of safety and tested his students in this area. Only those who achieved high marks were allowed to operate all the woodworking machinery. In regards to the planer, the teacher could not remember any particular instructions on what to do if the planer was clogged, as this was a very rare occurrence. His advice in the past was to bang on the dust collector from the outside.</p>

Liability	<p>The student’s parents sued the teacher, claiming that he was negligent in failing to properly instruct the student in the use of a planer, i.e., to clearly advise the student that it was highly dangerous to attempt to clear chips and sawdust from the planer while it was still running. They also alleged that the School District was negligent in that it did not provide a properly guarded planer (a screwed-on metal guard vs. the existing rubber flap).</p> <p>During the two years following the accident, the student underwent nine surgical procedures. Although she made a good recovery, she will be permanently limited in performing manual tasks that require dexterity in both hands. Consequently, her ability to earn income could be negatively impacted.</p> <p>After hearing the evidence, the court concluded that:</p> <ul style="list-style-type: none"> <li>• the teacher omitted to give adequate instruction on the dangers of lifting the flap and manually unclogging the planer while it was operating. This omission amounted to negligence.</li> <li>• the student, in failing to heed the instructions to turn off the machine before lifting the flap and clearing the shavings, was also negligent.</li> <li>• the School District, in failing to install a metal guard over the opening of the cover, was also negligent.</li> </ul> <p>The court split financial responsibility of negligence three ways: teacher – 20%; School District – 20%; and student – 60%. Because the School District was vicariously liable for the negligence of the teacher, it paid 40% of the damages. The student did not receive compensation for her share of the damages.</p>
-----------	--

Case No. 3	<b>Hand Injury</b>
Location	Wood Shop
Incident	A student was injured when the push stick he was using slipped off the end of the wood causing his left hand to go over the front of the board and come in contact with the knives of the jointer.
Circumstances	The student was familiar with the operation of the jointer, having received proper instruction in its safe operation. There was no defect in the jointer, but the push stick was defective.
Liability	The court concluded that the student was 65% contributorily negligent because the student should have examined the push stick before using it. The teacher was assessed 35% negligent as proper precautions had not been taken to ensure that defective or damaged push sticks were not available for student use.

Case No. 4	<b>Leg Injury</b>
Location	Wood Shop
Incident	While two students were standing talking in front of a revolving sanding wheel, one student flicked a chisel blade up and down close to the sanding wheel. The chisel blade hit the perimeter of the sanding wheel and became temporarily embedded in the wood. Centrifugal force caused the chisel to spring downward. It penetrated the student's right thigh, severing his femoral artery.
Circumstances	<p>The student's parents sued the teacher and the School District for negligence. They suggested that the teacher was not in the classroom at the time of the accident, and that the sanding wheel was revolving at too high a speed.</p> <p>During the proceedings, the court found that:</p> <ul style="list-style-type: none"> <li>• the teacher had warned the student, many times, to return to his bench after obtaining a tool;</li> <li>• the sanding machine was not dangerous and did not require a guard;</li> <li>• a wood chisel is not needed while using a sanding machine;</li> <li>• the student had used the machine 15 to 20 times without incident;</li> <li>• the student had been given sufficient warning as to the nature of the machines in the shop;</li> <li>• the operation of the sander did not lead to the injury; and</li> <li>• the injury had been caused by the student holding the tool too close to the revolving wheel.</li> </ul> <p>The court found that the teacher had met the standard of care required of him. It also dismissed the allegation that the sanding wheel was revolving at an excessive speed (840 rpm).</p>
Liability	The court determined that the student was solely responsible for his injury. Case dismissed.

Case No. 5	<b>Hand Injury</b>
Location	Wood Shop
Incident	An 18-year old deaf student suffered serious injury to his left hand when he touched the unguarded blade of a circular power table saw that he was using.
Circumstances	The student was directed by the teacher to trim some chest drawers. The operation was not normally done on chest drawers, however, and required the removal of the safety guard. The teacher showed the student two cuts and watched him make one or two as well. The teacher then moved about 15-25 feet away to work on another bench where he could keep his eye on the student. After a short period of time, the student let his attention drift and his hand struck the saw.

<p>Liability</p>	<p>The judge held that performing the operation with an unguarded saw was dangerous and that the duty of care required of the teacher was not met in these circumstances where the student had special needs. The judge reasoned that a higher duty of care is owed to such students because one cannot warn them quickly enough of what may be wrong. The responsibility of negligence was split two ways: teacher – 60%, student – 40%.</p> <p>On appeal, the Appellate Court overturned the trial judge’s decision. On further appeal, the Supreme Court of Canada concluded that the Appeal Court’s decision was incorrect. It applied a higher duty of care and supervision for deaf students who are subject to a greater risk of injury than other students who could be warned quickly enough to avoid such an injury.</p> <p>This case suggests that closer supervision may be necessary for special needs students who are more vulnerable to risk of injury because the usual precautions may be ineffective.</p>
------------------	--

<p>Case No. 6</p>	<p><b>Hand Injury</b></p>
<p>Location</p>	<p>Wood Shop</p>
<p>Incident</p>	<p>A 17-year old student lost the tips of three fingers on a jointer.</p>
<p>Circumstances</p>	<p>The accident occurred while the student was taking Construction 11. At the beginning of the course, the teacher had provided students with a 15-page set of safety instructions detailing the rules for each machine. They were also given a textbook that included a description and illustration of a jointer and safety tips on its use. Throughout the course, the importance of safety was stressed. During demonstrations by the teacher of the various tools in the shop, including the jointer, the student had been absent due to illness. However, this same student passed all the tests administered during the course, including those on safety. There was also evidence to suggest that the student had used the jointer in a previous woodworking course, as well as about 15 times in the current course before the accident occurred.</p>
<p>Liability</p>	<p>The trial judge found that even though the student used the jointer in an improper fashion the teacher was negligent because he failed to ensure that the student received the necessary instructions required to operate the equipment safely through teacher demonstration.</p> <p>The Court of Appeal agreed with the trial judge in finding the teacher negligent. There was evidence to support the need for make-up instruction to students who were absent during teacher demonstrations.</p>